

**KING DOM OF LESOTHO MINISTRY OF WORKS**

**SOUTHERN PERIMETER ROAD  
DESIGN MEMORANDUM**

**AXLE LOADS**

**PRC Harris, Inc. NEW YORK**

**KINGDOM OF LESOTHO MINISTRY OF WORKS**

**SOUTHERN PERIMETER ROAD  
DESIGN MEMORANDUM**

**AXLE LOADS**

**PRC Harris, Inc. NEW YORK**

## TABLE OF CONTENTS

- 1.0 INTRODUCTION
- 2.0 SURVEY PROCEDURE
  - 2.1 Traffic Counting
  - 2.2 Commercial Vehicle Weighing and Measuring
- 3.0 DESCRIPTION OF WEIGHING EQUIPMENT
  - 3.1 Dial Indicator
  - 3.2 Accuracy
- 4.0 VEHICLE WEIGHT ANALYSIS
  - 4.1 Determination of Present Truck Fleet Characteristics
    - 4.1.1 Vehicle Makers
    - 4.1.2 Vehicle Occupancy
    - 4.1.3 Tare Weight and Gross Vehicle Weight
    - 4.1.4 Vehicle Ownership
    - 4.1.5 Packaging
    - 4.1.6 Number of Axles
  - 4.2 Vehicle Loads in Lesotho
- 5.0 TRAFFIC ANALYSIS
- 6.0 ORIGIN - DESTINATION SURVEY
  
- APPENDIX 1 Survey Forms
- APPENDIX 2 Range & Consistency Checks
- APPENDIX 3 Traffic Count Tabulations
- APPENDIX 4 Bibliography

## LIST OF TABLES

- 2.1 Schedule of Surveys
- 2.2 Maseru Traffic Counts: 12 Hour Flows as a Percentage of 16 Hour Flows.
  
- 4.1 Vehicle Makers
- 4.2 Vehicle Occupancy
- 4.3 Vehicle Ownership
- 4.4 Distribution of Number of Axles
- 4.5 Distribution of Axles per 100 Vehicles
- 4.6 Percentage of Trucks with Number of Axles
- 4.7 Calculation of No. of Standard Axles per 100 Vehicles
- 4.8 Distribution of GVW by Commodity Classification
  
- 5.1 Traffic Growth Rates
- 5.2 Traffic Projections Mohales Hoek to Qacha's Nek
  
- 6.1 Origin - Destination Matrix as Surveyed
- 6.2 Origin - Destination Correction Matrix
- 6.3 Origin - Destination Matrix Corrected

## LIST OF FIGURES

- 2.1 Location of Survey Sites
- 2.2 The Weighing in Progress
- 2.3 The Weighing Equipment
  
- 3.1 The Weighing Unit Platform
- 3.2 The Load Cells Wiring Diagram
  
- 4.1 Vehicle Tare and GVW
- 4.2 Type of Packaging
- 4.3 Type of Commodities Transported
- 4.4 Axle Loads of 2 Axle Trucks
- 4.5 Total Gross Vehicle Weight
- 4.6 Cumulative Percentages of GVW by Commodity
  
- 5.1 Traffic Volumes and Forecasts

## 1.0

### INTRODUCTION

At the request of the Ministry of Works of the Kingdom of Lesotho, PRC Harris Inc. established a vehicle weight survey and traffic analysis as an addition to the design work already in hand for the Southern Perimeter Road. The principal purpose of the survey was to collect axle load data in the field to be used in the design of the pavement of that road.

Notwithstanding that the survey was a part of the design study for the Southern Perimeter Road, the locations of the survey sites were distributed throughout the country to determine any variations in traffic composition and vehicle weights which may occur between different parts of the country, and to obtain the maximum number of axle load readings.

The on-site measurement of axle loads for highway design studies in developing countries is a relatively new procedure. Formerly standard tables which give the number of "standard axles" per 100 vehicles have been used. These tables do not take sufficient account of the variations in vehicle loading characteristics which occur from one country to another and indeed from one place to another.

Frequently, in countries where there are either no vehicle weight restrictions, or such restrictions as exist are not enforced, excessive overloading of vehicles can be observed. In Lesotho, it can be shown with the aid of the results of this weighing programme that the truck overloading in general, is not a serious problem.

In addition to the weighing of vehicles, manual classified traffic counts were undertaken. On the Southern Perimeter Road they have been used to compare the forecasts given in the report of the Feasibility Study for this road with the actual situation in 1979 so that if necessary, adjustments could be made to the forecasts. In the event it was found that the counts gave reasonably close agreement with the forecasts. This showed that these forecasts could be used with greater confidence in the design of the new road.

In fact, several very heavy vehicles were observed together with some small vehicles whose load was too great for safety, but as the tables show these represented only a small percentage of the total number of commercial vehicles. This does not mean that axle load enforcement is not necessary, it is, but the topography of Lesotho is such that the geometric design standards of many roads are such that overloaded vehicles would be unable to negotiate certain stretches of road.

As the road standards improve there will be a tendency to use heavier vehicles with the result that pavement deterioration could ensue. It is recommended that a program to enforce axle load limits be established in order to protect the existing road pavements, but this limit should be set sufficiently high to avoid increasing vehicle operating costs significantly.

## 2.0

### SURVEY PROCEDURE

The survey work was undertaken during November and December 1979 as shown in Table 2.1

TABLE 2.1 SCHEDULE OF SURVEYS

SITE NO.	LOCATION	DATE	DIRECTION
1	Maseru Border	14/11/79	E
1	Maseru Border	16/11/79	W
2	Khubetsoana	19/11/79	N -S
3	Masianokeng	20/11/79	N -S
4	Mafeteng Phahameng	22/11/79	N -S
5	Mafeteng Van Royen	23/11/79	E -W
6	Mohales Hoek	26/11/79	N -S
7	Quthing	27/11/79	E -W
8	Qachas Nek	29/11/79	E -W
9	T-Y	3/12/79	N -S
10	Leribe	4/12/79	N -S
11	Maputose	6/12/79	E -W
3*	Masianokeng	20/11/79	N -S

\*Station 3 was resurveyed for two hours on 20/11/79 since an accident interrupted the work on 19/11/79.

At the design stage of the study it was anticipated that surveys in 10 locations spread throughout the country would give an adequate number of axle load readings together with information on the size of trucks. In the event it was decided to increase the number of sites from 10 to 11 to take account of the substantial flow of vehicles to and from the Republic of South Africa at Maputsoe/Ficksburg. The locations of the sites are shown in Figure 2.1.

The sites were chosen so that all significant long-distance traffic flows between all the regions of the country would be intercepted at at least one location.

Since the present traffic flow on the existing road from Mohale's Hoek to Qacha's Nek is very low, three survey stations were considered adequate to determine the traffic characteristics on that road. In addition, three sites were located on all the roads approaching Maseru because it was anticipated that the highest traffic flows in the country would be observed here. The remaining sites were located at Mafeteng, T-Y and Leribe together with Maputsoe as explained above. These sites were located so that if required in the future any relationship between the total weight of goods produced and consumed by commodity type and population in any given region could be determined.

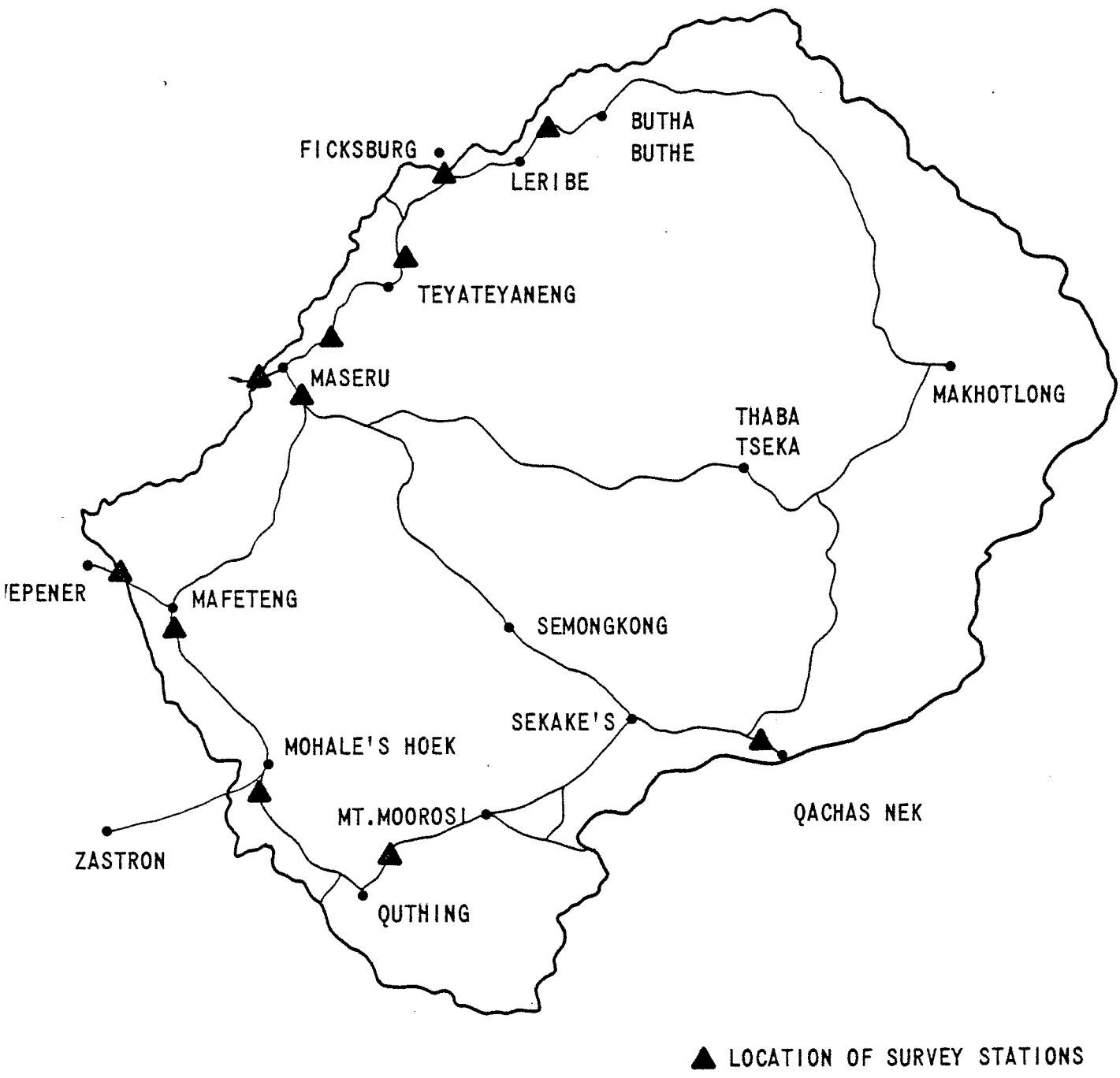

LOCATION OF SURVEY STATIONS

FIGURE 2.1

The detailed locations were chosen so that wherever possible, trucks could be stopped and weighed without interrupting the traffic flow and so that trucks waiting to be weighed could do so without causing a hazard to other road users.

It was decided to restrict the hours of survey work to 12 per day. This was done to enable the work to be completed during the hours of daylight and to be undertaken by one shift of interviewers. In order to be sure that only on insignificant proportion of the traffic occurs outside this 12 hour period. 16 hour traffic counts were undertaken near Maseru. The proportion of the total 16 hour traffic flow which occurs during the 12 hour period from 06.00 to 18.00 is shown in Table 2.2.

TABLE 2.2 MASERU TRAFFIC COUNTS: 12 HOUR FLOWS AS A PERCENTAGE OF 16 HOUR FLOWS

SITE NO.	12 HOUR FLOW	16 HOUR FLOW	12 HOUR FLOW AS AS % OF 16 HOUR
1 (E)*	448	578	77.5
1 (W)*	522	604	86.4
2 (N)	574	655	87.6
2 (S)	483	568	85.0
3 (N)+	856	1065	80.4
3 (S)+	1012	1174	86.2
Overall weighted average			83.9

\*Average values of 15 and 16 November 1979

+Account taken of accident at their site on November 20, 1979

The survey team consisted of the following people:

- a. Supervisor (permanent staff of PRC Harris)
- b. Team Leader (1)
- c. Traffic counters (2)
- d. Vehicle measurers (2)
- e. Driver (1)
- f. Reserves (2)
- g. Policemen (1 or 2)

Although the team members were assigned to specific tasks, each (except the supervisor) was able to interchange with other people in order to have more variety of work. As is normal in this type of survey, the work was confined to weekdays.

## 2.1 TRAFFIC COUNTING

The traffic flows were recorded manually on to the forms shown in Appendix 1. These forms were changed every half-hour, and the persons counting were relieved every hour. This procedure ensured accurate counting. Initially, some difficulty was experienced by the enumerators in classifying the various vehicle types. In this case they were referred to the diagrams to be found on the reverse side of the survey sheet. See Appendix 1.

## 2.2 COMMERCIAL VEHICLE WEIGHING AND MEASURING

All the details concerning commercial vehicles were recorded on the form shown in Appendix 1. All the information on the top line of the form was completed before the interview started and the truck was weighed. In many cases there was no easily recordable number on the vehicle in which case this space was left blank.

It was not possible to obtain any information on the age of the vehicle from the driver since the registration document is not normally carried on the vehicle. The number of occupants was the total number of people present in or on the vehicle for whatever purpose. No attempt was made to separate those people employed by the owner of the vehicle from those who were not.

The two spaces for tare weight "T" and GVW "V" were filled by inspecting the plate on the side of the vehicle. This plate is normally to be found on the chassis of the truck on the left hand side. Some vehicles of Lesotho registration did not have such plates and in this case the spaces were left blank.

The origin and destination of the trip were obtained by asking the driver. In "multiple drop" trips where the vehicle in delivering one or two items to various places, the next planned stop was taken to be the destination of the trip, similarly the last stop was assumed to be the origin. (This occurred only in a very small number of cases)

The type of goods carried was normally determined by inspection. Occasionally, however, it was necessary to ask the driver, for example where the merchandise was in unmarked bags or in a closed vehicle.

In every case a three or four word description of the goods was noted. This description also noted the type of packaging where this was not obvious from the goods.

The truck type and size of load were determined by inspection. Any specially constructed truck bodies e.g. tanks, were coded as "special." The size of load became particularly important when the vehicle was empty in this case the analysis was carried out in a slightly different way (See Section 4) and where the vehicle was apparently overloaded. If any truck weight enforcement were to be considered it is only the apparently overloaded trucks which would normally be weighed with a view to prosecution.

The remainder of the information, except the number of tyres on each axle, was obtained by measurements. The vehicles were weighed as shown in Figures 2.2 and 2.3. The weights of both the left and right hand wheels were recorded on the form before the driver was asked to move his vehicle so that the next axle was placed on the equipment. The dimensions of the vehicle were obtained by measurement with a standard surveyor's tape.

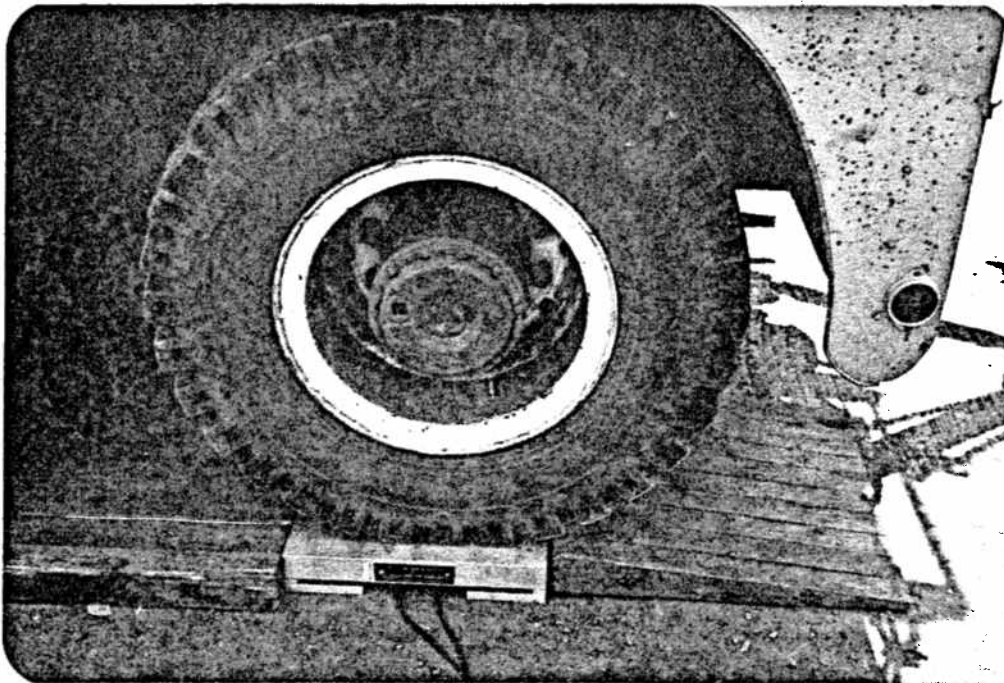

THE WEIGHING IN PROGRESS

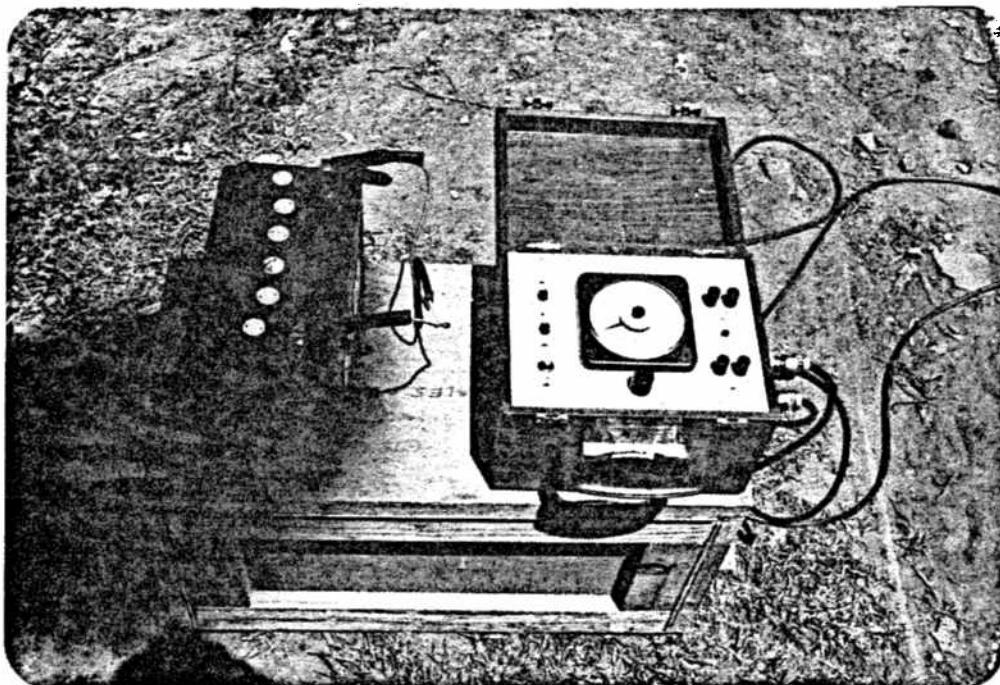
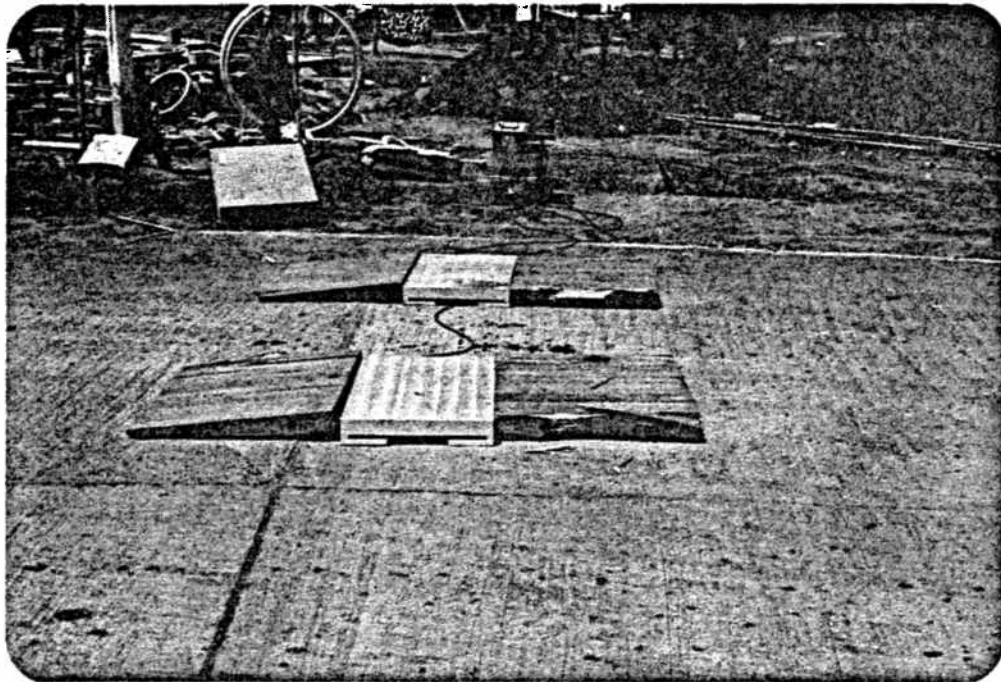

THE WEIGHING EQUIPMENT

FIGURE 2.3

### 3.0

#### DESCRIPTION OF WEIGHING EQUIPMENT

The weighing equipment consisted of two almost identical platforms which were manufactured in the United Kingdom to a design prepared by the Transport and Road Research Laboratory. (See RRL Report No. LR391). The two platforms differed only in the wiring connections.

The platforms were constructed from aluminum alloy (HE14 Duraluminum). this material was chosen because of its high stiffness to weight ratio and good anti-corrosive properties.

The platform consisted of two plates which were separated by six load cells. The design of the plates were as shown in Figure 3.1. Each platform was designed for a load of up to 10,000 kg. The surface area of the bottom plate was 2500 cm so that the maximum contact pressure would not exceed 4 kg/cm<sup>2</sup>

The body of the load cells was mild steel which was used because the resins used to attach strain gauges adhere very well to it. Each load cell was 38mm diameter and 40mm long with a 13mm diameter hole through the center to accommodate the bolts securing the loading platform to the lower platform.

The cross-sectional area of one load cell was adequate to support the full working load of 10,000 kg of the whole weighing unit and when stressed in this way the body of the load cell is well below the yield point of the material. This ensures that any hysteresis effects are negligible.

Each load cell had four 1000 ohm 6mm linear foil strain gauges, two "live" ones being cemented in the longitudinal direction, and two "dummy" ones (transversely) in the Poisson orientation. The gauges were cemented to the cell body with an epoxy resin adhesive and were connected in a Wheatstone bridge circuit to compensate for possible bending stress in the cell body during loading temperature effects.

In order to minimize errors caused by eccentricity of the wheel loads applied to the loading platform, the strain gauge bridges of the six load cells were connected in parallel. The wiring diagram is shown in Figure 3.2. Two coats of epoxy resin adhesive and a coating of silicone based sealant applied to the strain gauges ensured a high resistance to leakage.

The calculated theoretical output of the weighing unit, based on the strain gauge manufacturers quoted factor of 2.10 was 1200 in for a 10,000 kg load with a 12 volt supply to the bridges.

A reduction in the shearing stresses at the points of support in both platforms was effected by the insertion of 3mm x 5cm washers at either end of the load cell. Additionally, 3mm hardboard discs were inserted to minimize stress concentrations in the Duralumin.

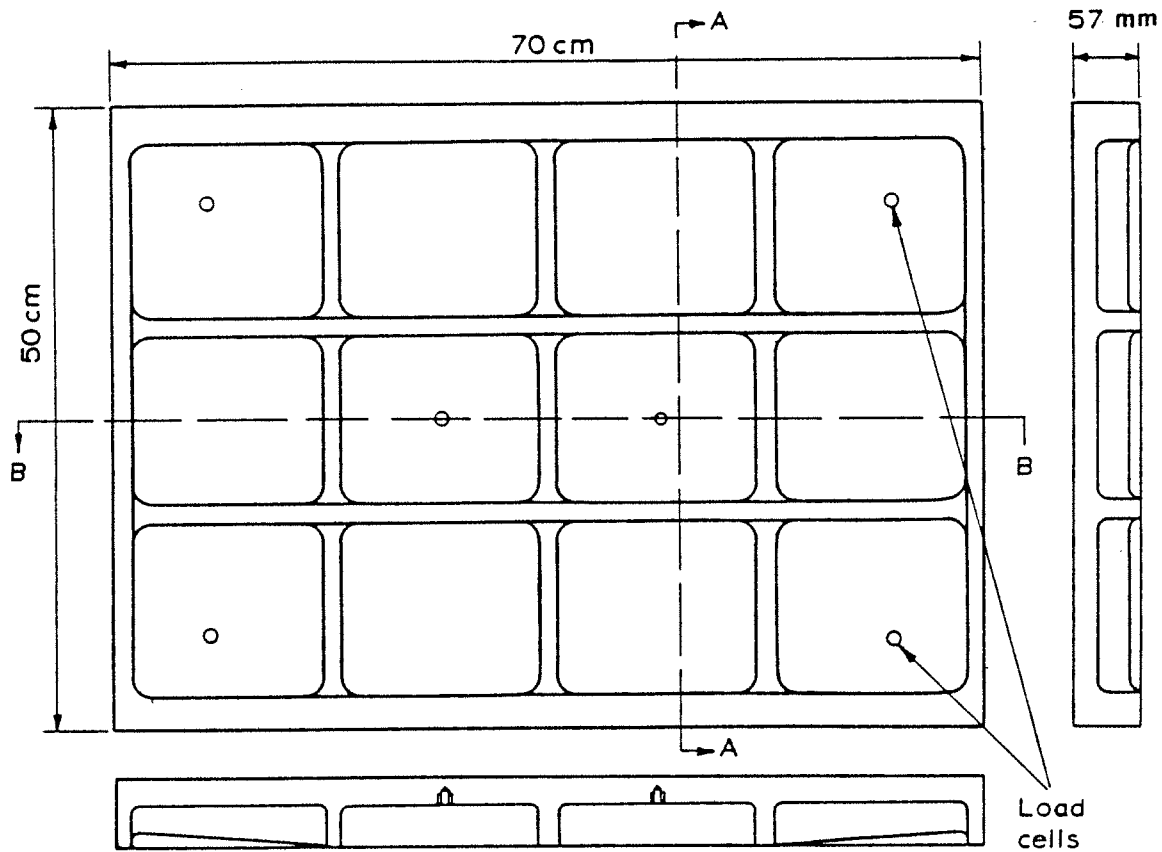

The loading (upper) platform

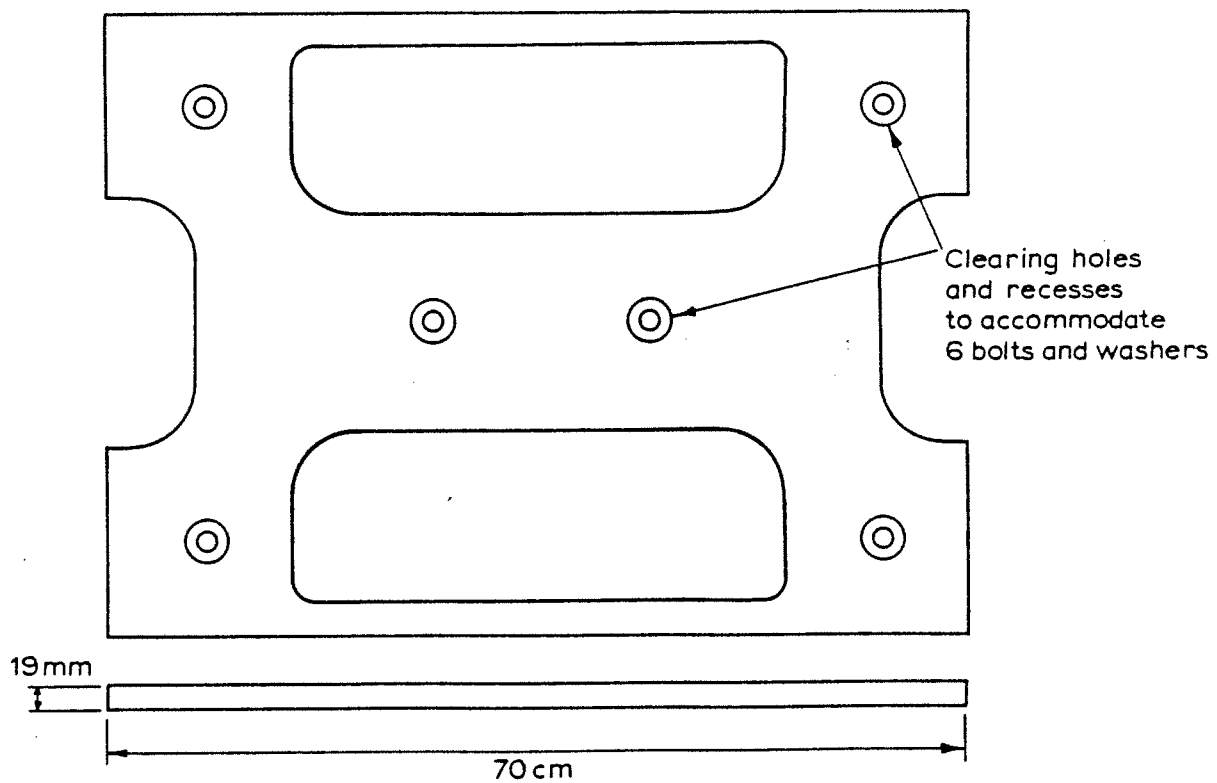

The lower platform

THE WEIGHING UNIT PLATFORM

FIGURE 3.1

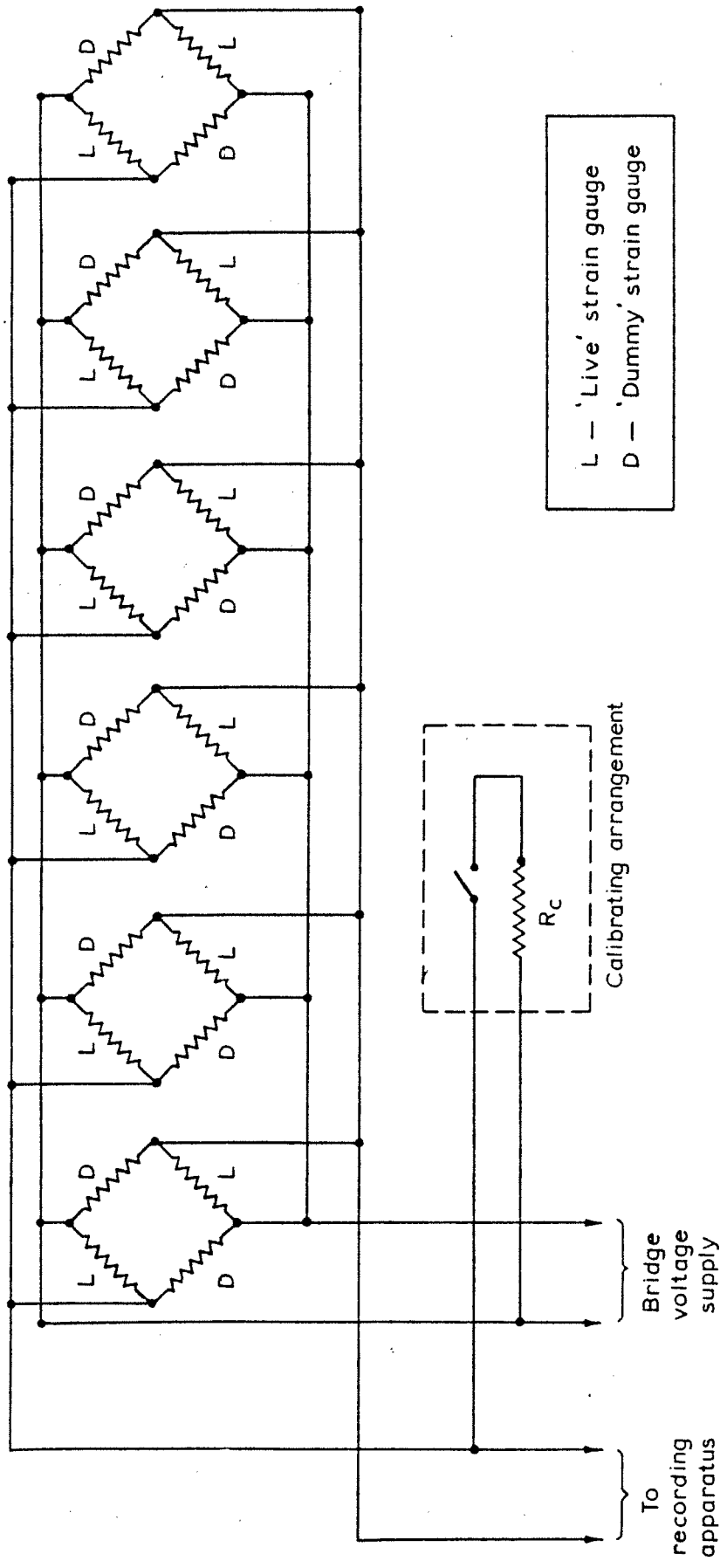

THE LOAD CELLS WIRING DIAGRAM

FIGURE 3.2

Flat aluminum bars were attached to the lower platform immediately below the long edge webs of the loading plate in order to reduce the gap between the two platforms to 3mm. An applied load near the edge of the loading platform caused this gap to close thus preventing overstressing in the edge webs. In addition, micro-switches were installed between the two plates in the middle of the long edges so that when the gap was about to close due to excessive overloading, a red warning light glowed on the measuring equipment.

Each of the six bolts holding the platforms together was pretensioned to 200 kg. This was checked before the start of weighing each day.

### 3.1 DIAL INDICATOR

A dial indicator consisting of an amplifier, a stabilizing circuit and a meter calibrated from 0 to 10,000 kg was used to indicate the weight applied to each weighing platform. The unit was powered by a 12 volt battery

### 3.2 ACCURACY

Prototype units have been laboratory checked and found to give an overall accuracy of  $\pm 2$  percent provided that

- a. The equipment was allowed to "settle down" for a period of about  $\frac{1}{2}$  hour under site temperature and humidity conditions.
- b. The zero (no load) readings were checked frequently and adjusted as necessary.
- c. The sensitivity of the apparatus was checked regularly using the calibrator sized.

Since these steps were followed on all occasions there can be a high level of confidence in the recorded vehicle weights.

## 4.0

### VEHICLE WEIGHT STUDY ANALYSIS

The analysis of the vehicle weight study focussed on the following issues:

1. What are the characteristics of the present truck fleet?
2. What are the present vehicle loads on the roads in Lesotho?

The survey included a total sample size of 1058 trucks. Several vehicles were weighed more than once, and many were of South African registration. The sample included 917 single units, 64 articulated, 33 truck & trailer combinations, 2 tractor units without trailers and 42 special vehicles mainly with tank bodies but this number also included breakdown vehicles, towing trucks and drilling rigs.

#### 4.1 DETERMINATION OF PRESENT TRUCK FLEET CHARACTERISTICS:

##### 4.1.1 VEHICLE MAKERS

Of the 1058 vehicles surveyed, Mercedes was shown to be the most popular make with 308 or 29% of the total. British Leyland was the second with 157.

TABLE 4.1 VEHICLE MAKERS

MAKE	NO. SURVEYED	%
Mercedes	308	29.1
Leyland	157	14.8
Toyota	142	13.4
Nissan	121	11.4
Isuzu	79	7.5
Ford	67	6.3
Other	184	17.5
TOTAL	1,058	100.0

The majority of the trucks examined were built or assembled in South Africa. The customs union between Lesotho and the Republic enables vehicles to travel across the frontiers between the two countries with a minimum of difficulty, thus there is no constraint on transport or development caused by limitations in the size or number of vehicles. If an operator needs a new vehicle or to hire one for any reason he merely goes to RSA and buys or rents one suitable to his needs. The only restriction on his freedom is that the vehicle has to be registered in Lesotho within a given period. This freedom of access to suitable commercial vehicles and spare parts is a great benefit to the citizens of Lesotho and is in sharp contrast to the situation pertaining in many developing countries where the supply of commercial vehicles and spare parts is regulated by government fiscal

policies. While this regulation may have some benefit to the overall balance of payments, the constraints imposed on freight transport are often severe and cause operating costs to be substantially higher than they might otherwise be.

#### 4.1.2 VEHICLE OCCUPANCY

The occupancy of commercial vehicles was as show in Table.4.2

TABLE 4.2 VEHICLE OCCUPANCY

NO. OF PERSONS INC. DRIVER	NO. OF VEHICLES	%
1	280	26.5
2	293	27.7
3	230	21.7
4 or more	245	24.1
<b>TOTAL</b>	<b>1058</b>	<b>100.0</b>

The average overall vehicle occupancy was 2.86

No attempt was made to determine whether the occupants other than the driver were employed by the owner of the vehicle since it was considered that this information would be unrealistic. However, children under 6 years old were not included in the count of occupants.

#### 4.1.3 TARE WEIGHT AND GROSS VEHICLE WEIGHT

The tare weight and maximum GVW for each vehicle were recorded in order to compare actual vehicle weights with plated maximum values. In the event there were so many vehicles with missing or illegible plates that this was not possible. Nevertheless, the tare and GVW for these vehicles where it was possible to record them are shown in Figure 4.1 It must be emphasized that these figures do not represent the load of the vehicle, merely the plated values. Figure 4.1 A shows a continuous chart demonstrating the fact that tare weights are fairly evenly distributed throughout the range of 4 to 20 tonnes. Figure 4.1 B on the other hand shows several discontinuities. These are caused by proportionally large numbers of vehicles in the 4-5 tonnes GVW and in the 11-14 tonnes ranges. There are also a large number in the 22-23 tonnes range.

#### 4.1.4 VEHICLE OWNERSHIP

The ownership of vehicles in Lesotho is shown in Table 4.3. The owners to be classified independently were determined by a visual examination of the survey forms before coding. The large number (685) of privately owned vehicles not otherwise classified demonstrates the large number of small private operators

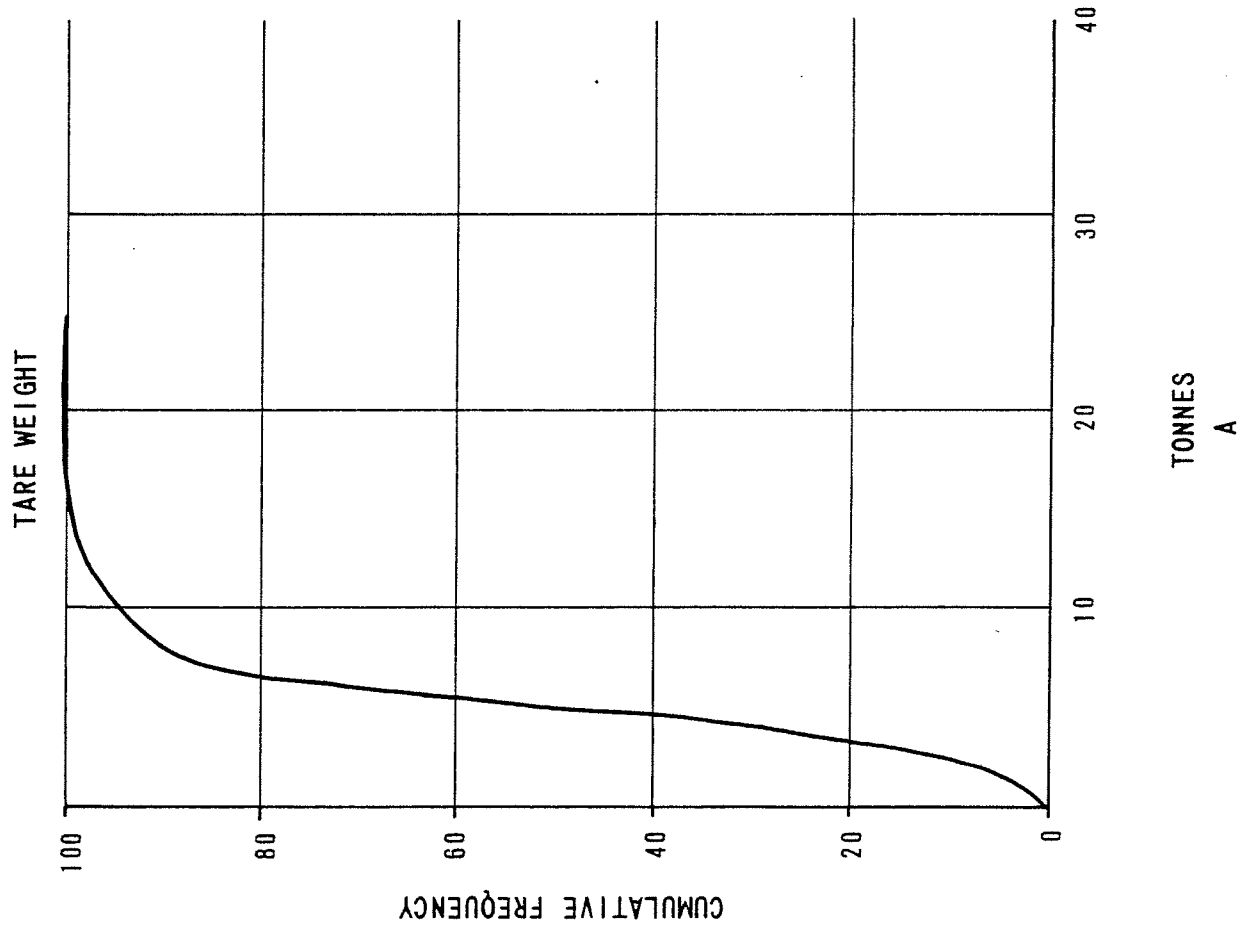

TONNES  
A

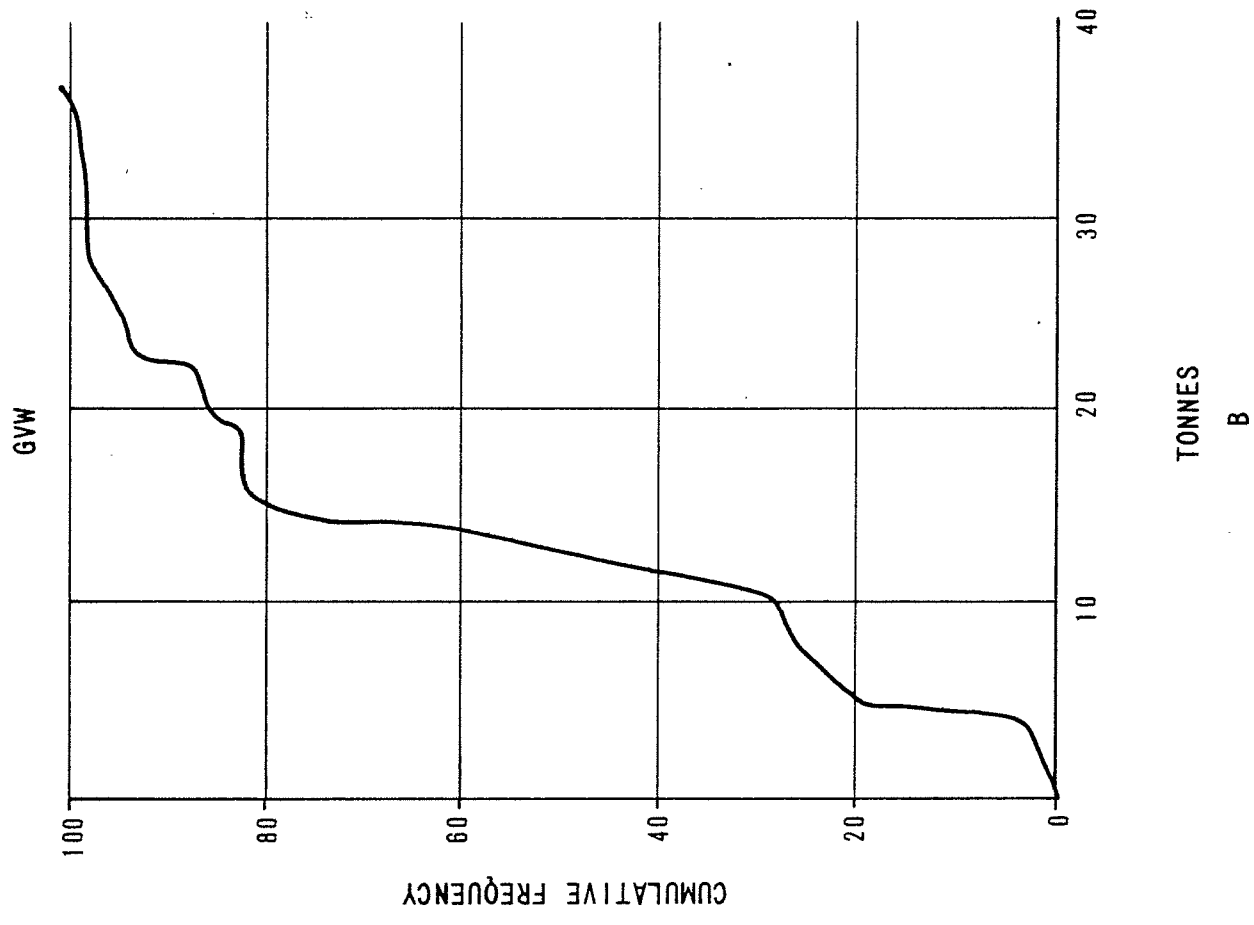

TONNES  
B

VEHICLE TARE AND GVW

FIGURE 4.1

using vehicles in Lesotho. Of the 1058 interviews only 72 were of Lesotho Government vehicles and 5 of South African Government vehicles.

TABLE 4.3 VEHICLE OWNERSHIP

OWNER	NO. OF INTERVIEWS	%
Lesotho Government	72	6.8
R.S.A. Government	5	0.5
Sasko	18	1.7
Frasers	37	3.5
Lesotho Milling	55	5.2
Nqoko	20	1.9
Lesotho Freight	28	2.6
Exley	10	0.9
Sunripe Fruit	5	0.5
Scribante	11	1.0
Owner driver	103	9.7
Other private ownership	685	64.7
<b>TOTAL</b>	<b>1058</b>	<b>100.0</b>

#### 4.1.5 PACKAGING

Figure 4.2 shows the distribution of packaging of loads in Lesotho. Bulk loads represent 48.5% of all types. This category includes such items as furniture without packing cases and machinery together with grain or aggregate carried in bulk. 25.8% of loads are in boxes and 23.8% in bags. 1.8% are transported in vessels which include milk drums, waters tankers etc. The numbers of vehicles carrying each commodity type are shown in Figure 4.3

#### 4.1.6 NUMBER OF AXLES

Table 4.4 shows the distribution of the number of axles throughout the truck fleet. This information was used in the calculation of the number of standard axles.

TABLE 4.4 DISTRIBUTION OF NUMBER OF AXLES

NO. OF AXLES	NO. OF VEHICLES	%
2	883	83.5
3	69	6.5
4	67	6.3
5	30	2.8
6	9	0.9
<b>TOTAL</b>	<b>1058</b>	<b>100.0</b>

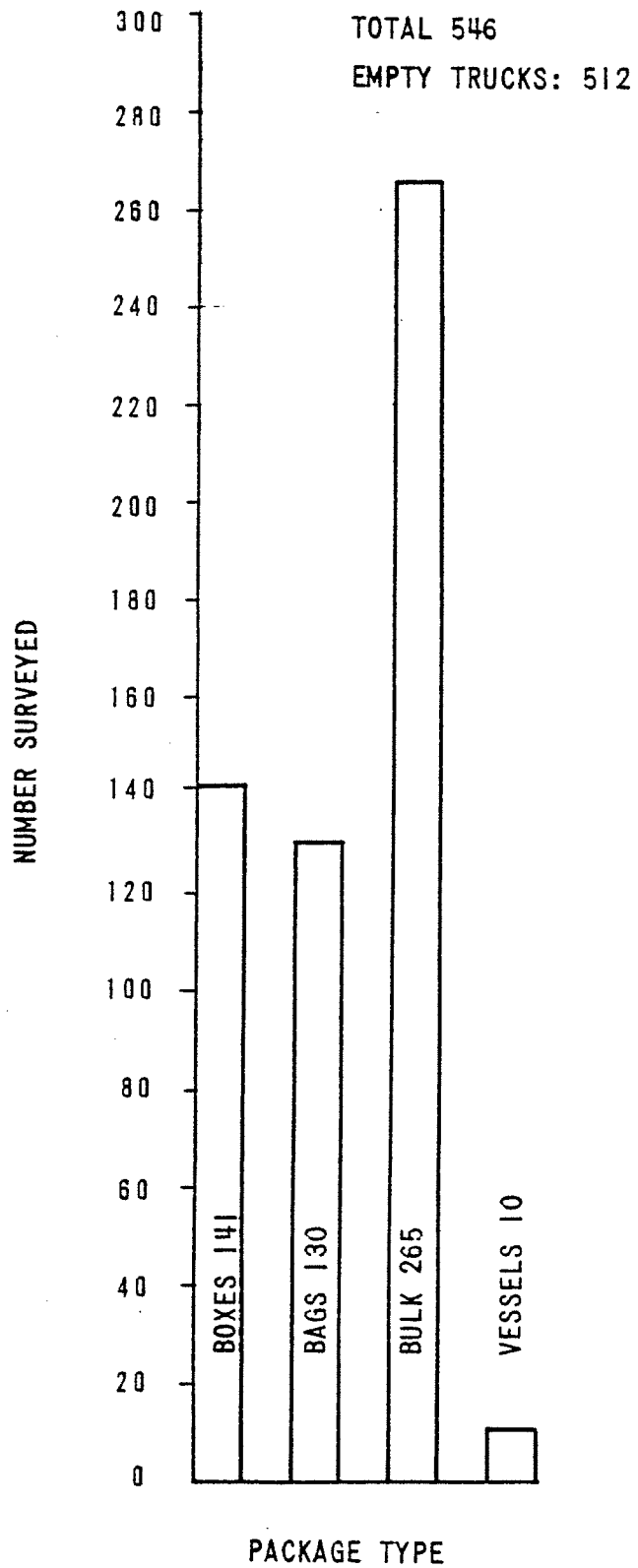

TYPE OF PACKAGING

FIGURE 4.2

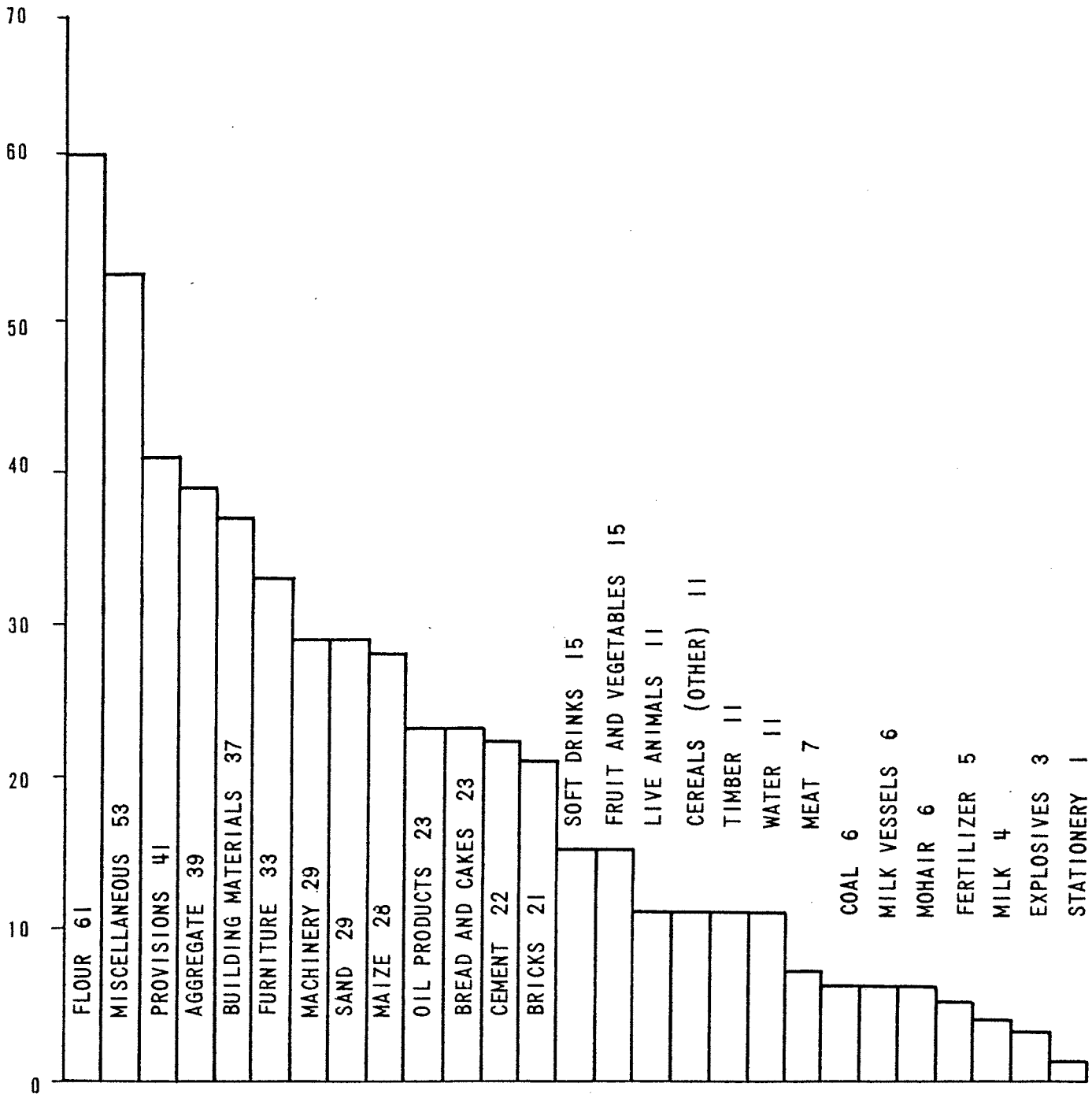

TYPE OF COMMODITIES TRANSPORTED

FIGURE 4.3

## 4.2 VEHICLE LOADS IN LESOTHO

One of the principal purposes of this survey was to determine the actual axle loading on the roads in Lesotho for input to the design of the Southern Perimeter Road and for future road designs. This section shows the method of calculation of the axle loading and then shows which types of vehicle demonstrate the highest loadings.

Table 4.5 shows that for every 100 trucks there are 231.5 axles. Table 4.6 shows the distribution of these 231.5 axles by load group. For example of all axles with loads of under 4 tonnes 61.7 of them are first axles, 53.7 second axles and so on which gives a total of 123.3 axles under 4 tonnes for every 100 trucks. The table also shows that there are 0.6 axles in every 100 trucks with a load of over 16 tonnes, and 17.5 with a load in excess of 10 tonnes.

TABLE 4.5 DISTRIBUTION OF AXLES PER 100 VEHICLES

AXLE NO.	NO. OF OCCURANCES
1	100.0
2	100.0
3	16.6
4	10.2
5	3.8
6	0.9
TOTAL	231.5

TABLE 4.6 PERCENTAGE OF TRUCKS WITH NUMBER OF AXLES AND AXLE LOADS

LOAD 000 KG	1	2	3	4	5	6	TOTAL	NO. EXCEEDING
Under 4	61.7	53.2	3.8	3.5	1.1		123.3	231.3
4-5	20.0	9.9	2.3	0.8	0.8	0.4	34.2	108.0
5-6	11.2	6.2	1.7	0.9	0.3	0.2	20.5	73.8
6-7	5.3	4.9	.3	0.4	0.1	0.1	12.1	53.3
7-8	1.4	3.5	1.2	0.7			6.8	41.2
8-9	0.1	4.6	1.2	0.9	0.2	0.1	7.1	34.4
9-10	0.1	5.8	2.5	1.1	0.3		9.8	27.3
10-11	0.1	4.3	1.2	0.7	0.5	0.1	6.9	12.5
11-12		4.4	0.7	0.6			5.7	10.6
12-13		1.1	0.4	0.1	0.1		1.7	4.9
13-14		1.2	0.2	0.2	0.2		1.8	3.2
14-15		0.3	0.1	0.1			0.5	1.4
15-16		0.3					0.3	0.9
16-17		0.2		0.2	0.2		0.6	0.6
TOTAL		100	99.9	16.6	10.2	3.8	0.9	231.3

Table 4.7 demonstrates the calculation of the total equivalent 18,000 pound single axles per 100 trucks following the method given by Yodes and Witczak. The data in the left-hand column shows the load classification groups. The table considers the number of trucks in each group per 100 trucks on the road. The summation of the number of loads times its appropriate factor yields the number of equivalent 18,000 pound single loads (EAL's) per 100 trucks on the road.

The table uses equivalence factors developed by AASHO. These factors are normally dependent upon the SN (Structure Numbers) at Pt (Servicability indices). However in this case the values were averaged for simplicity since the variations are very small. (Cf. Road Note 29)

The final figure of 144.55 was input to the pavement design process.

TABLE 4.7 CALCULATION OF NO. OF STANDARD AXLES PER 100 VEHICLES

AXLE LOAD		SINGLE AXLES PER 100 TRUCKS		
KIPS	TONNES	NUMBER	F	N x F
2	907			
4	1814			
6	2720			
8	3630	123.3	0.03	3.70
10	4540	34.2	0.08	2.74
12	5440	20.5	0.18	3.69
14	6350	12.1	0.35	4.24
16	7260	6.8	0.61	4.15
17	8160	7.1	1.28	9.09
20	9070	9.8	1.93	18.91
22	9980			
24	10890	6.9	3.33	22.98
26	11790	5.7	4.68	26.68
28	12700	1.7	6.42	10.91
30	13610	1.8	8.65	15.57
32	14510	0.5	11.46	5.73
34	15420	0.3	14.97	4.49
36	16330	0.6	19.28	11.57
38	17240			
TOTAL				144.55

The analysis of the axle weighing survey data is shown in Figures 4.4 to 4.6. Figure 4.4 shows the cumulative percentage of vehicle weights for all two axle trucks. All front axles are less than 10 tonnes while 90% of trucks have rear axles below 10 tonnes, 98% less than 12 tonnes.

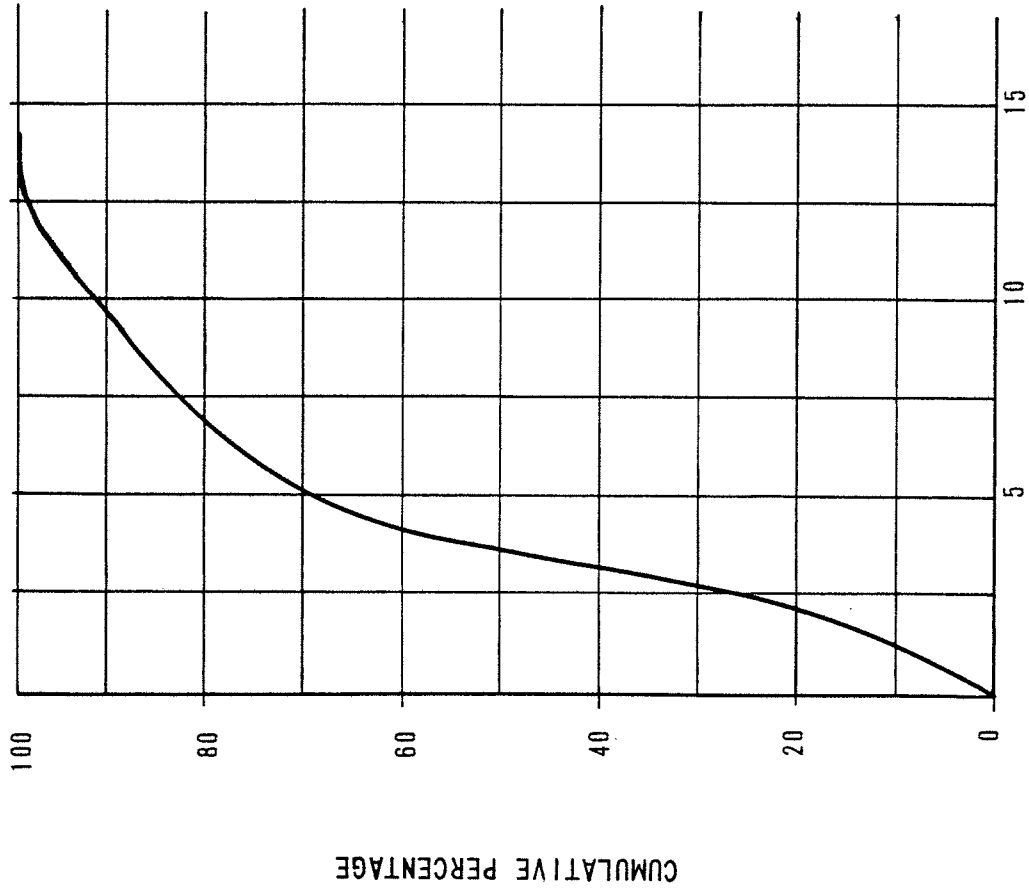
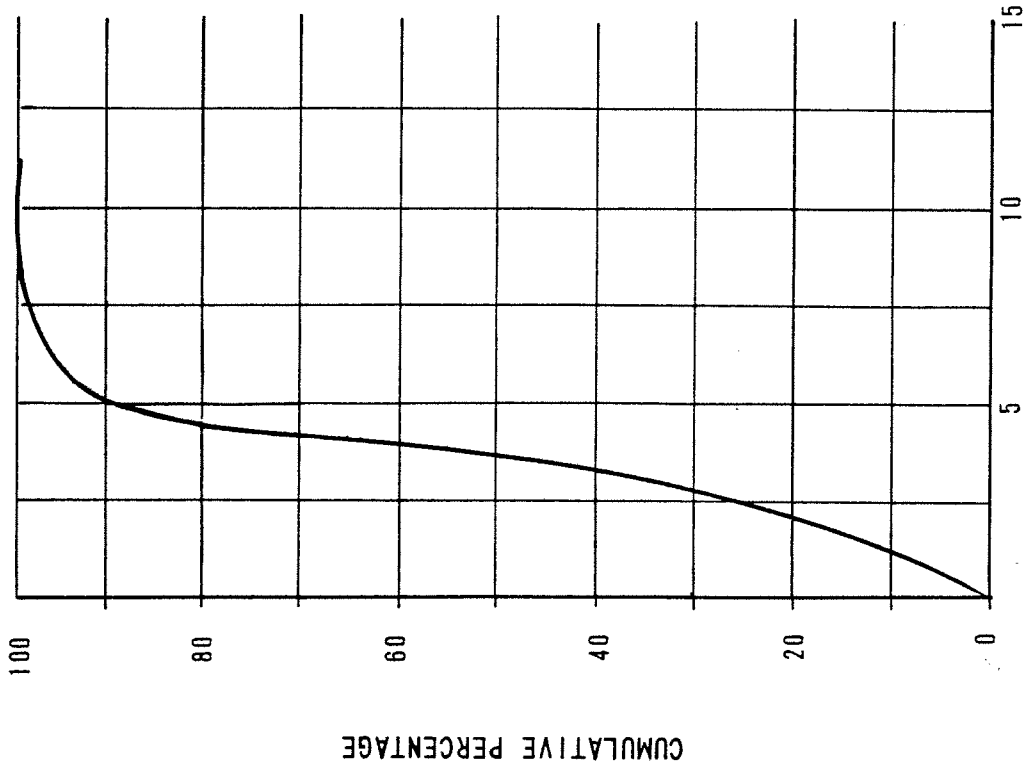

AXLE LOADS OF 2 AXLE TRUCKS

FIGURE 4.4

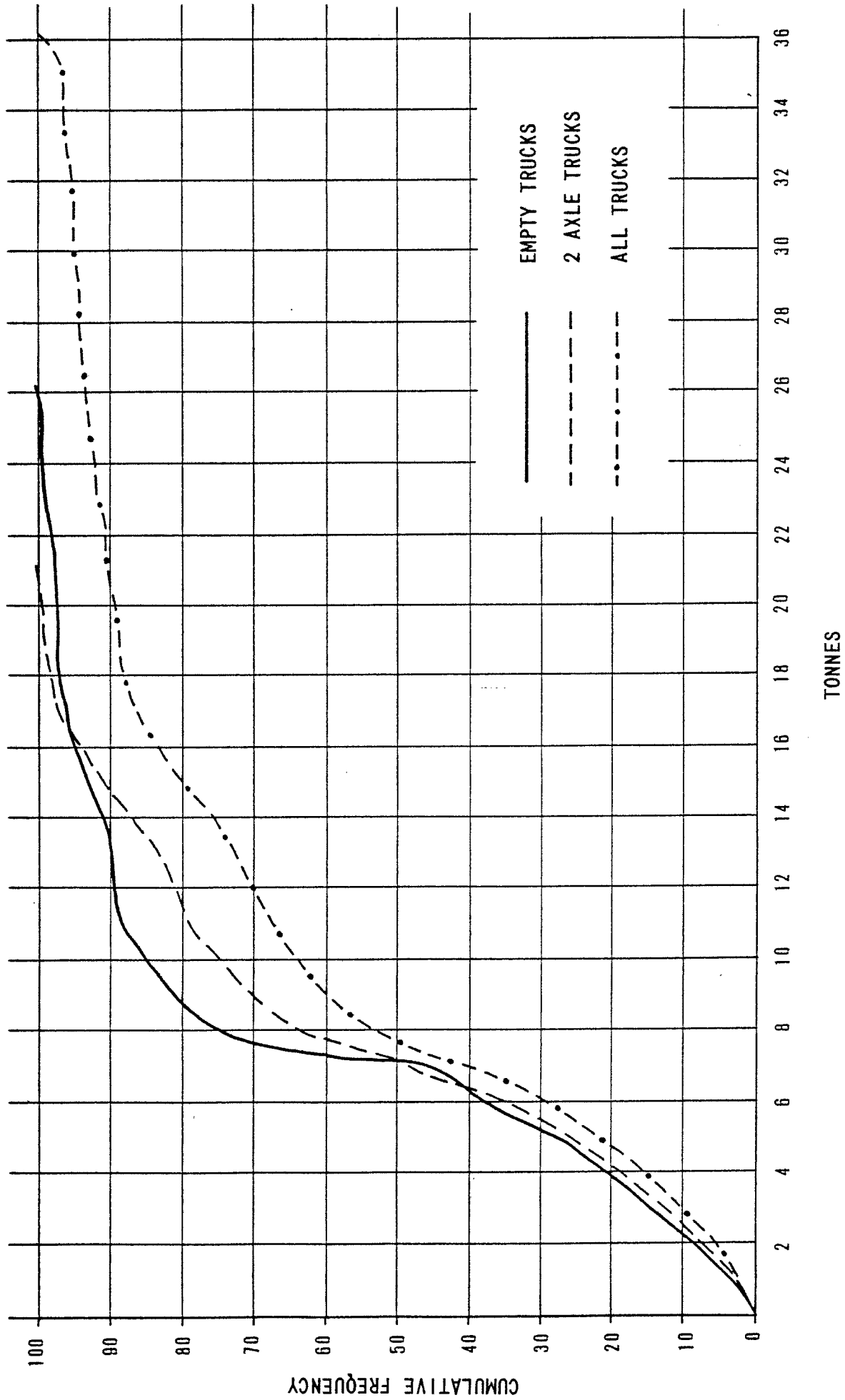

TOTAL GROSS VEHICLE WEIGHT

TONNES

FIGURE 4.5

MAIZE

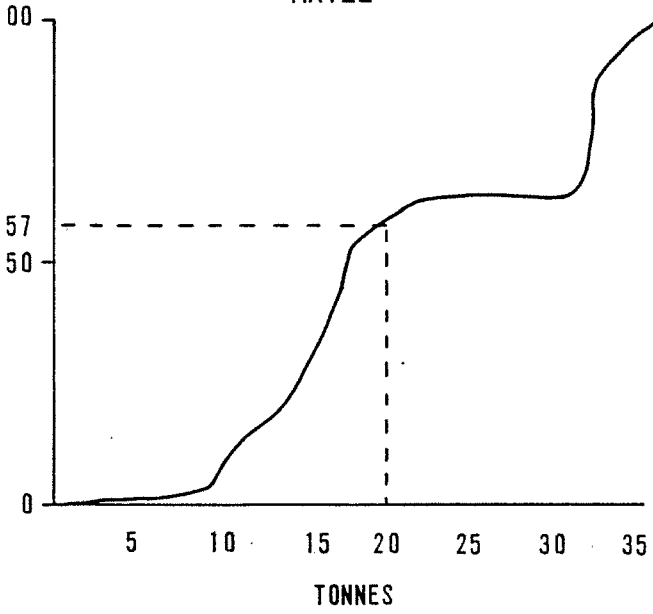

FLOUR

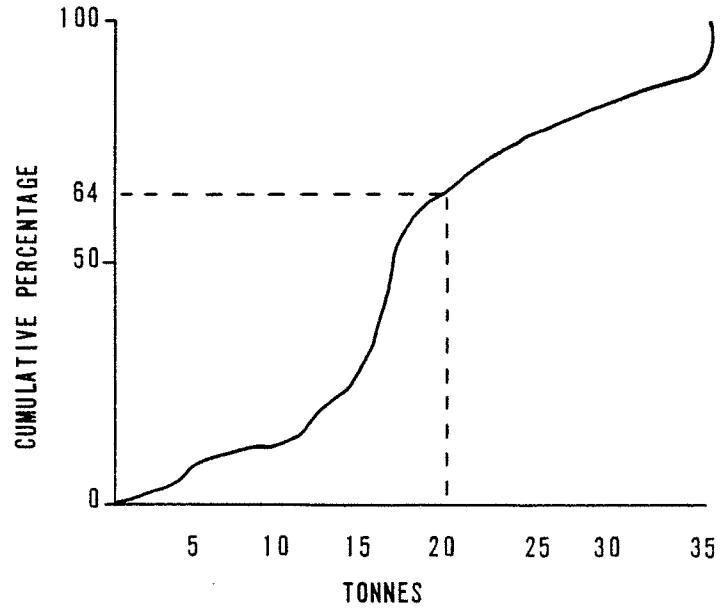

AGGREGATE

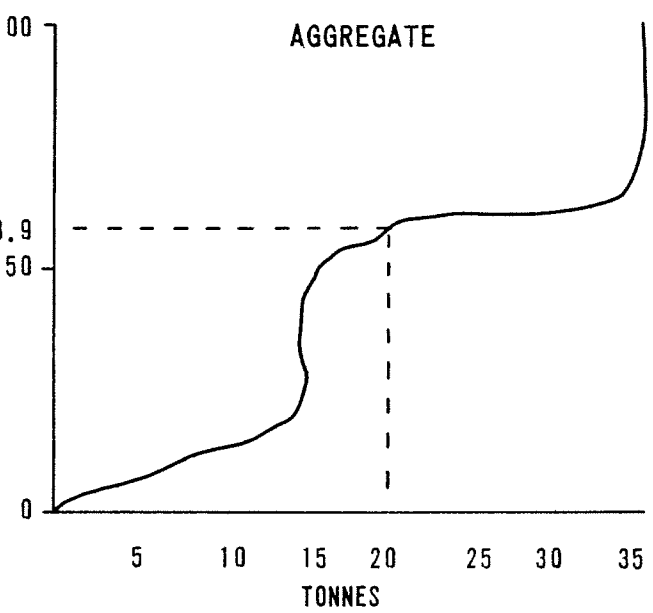

SAND

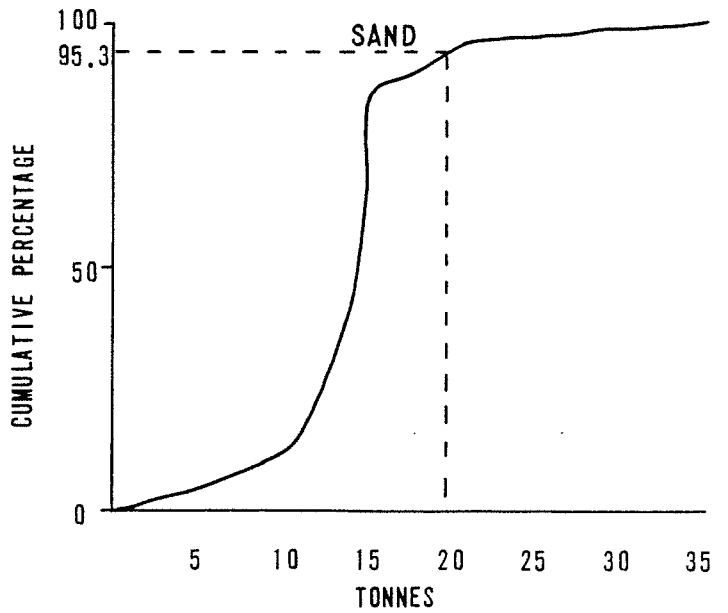

OIL PRODUCTS

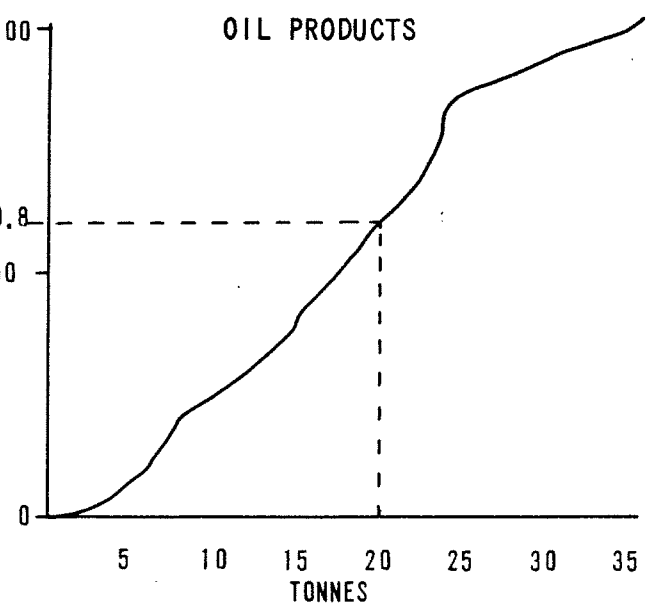

ALL LOADED TRUCKS

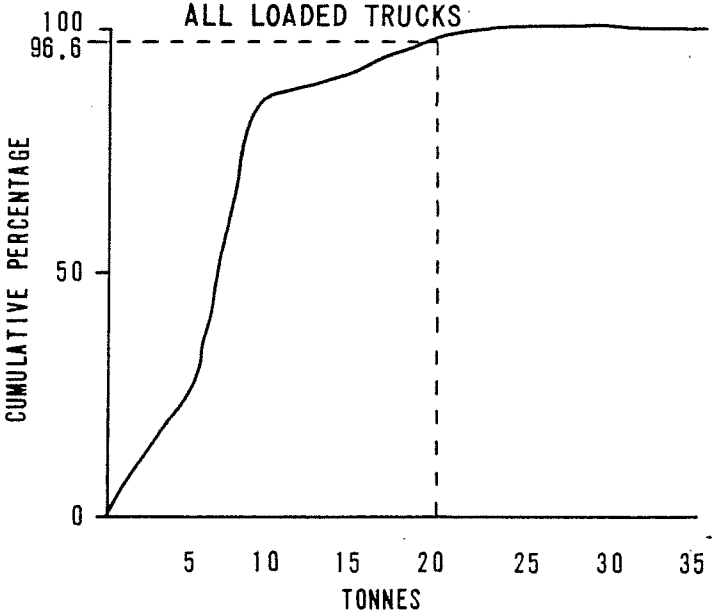

CUMULATIVE PERCENTAGES OF GWV BY COMMODITY

Figure 4.5 shows comparisons of gross weights for empty trucks, full two axle trucks and all trucks. Empty trucks have a median gross weight of 7 tonnes while all trucks together have a median gross weight of 7.8 tonnes. Two axle trucks also have a median gross weight of 7 tonnes.

The visual classification indicated that of the 1058 trucks which were stopped 512 were empty, i.e. 49%.

Figure 4.6 presents the cumulative frequency distribution of gross weights for trucks carrying various commodities. This figure clearly shows that of those categories specially analyzed the heaviest trucks are those carrying maize, aggregate and oil products.

However, the difference between the loads of the various commodities is small and any axle load enforcement would have to be applied to vehicles carrying all commodities.

Table 4.8 shows the distribution of gross vehicle weights by commodity classification.

TABLE 4.8 DISTRIBUTION OF GVW BY COMMODITY CLASSIFICATION

COMMODITY	# VEHICLES WEIGHED	GVW TONNES		
		LESS THAN 15	15-20	OVER 20
Maize	28	6	10	12
Live Animals	11	10	1	0
Meat	7	5	0	2
Cereals (other)	11	7	2	2
Flour	61	15	24	22
Provisions	41	35	5	1
Fertilizer	5	2	3	0
Oil Products	23	7	7	9
Soft Drinks	15	11	1	3
Machines	29	22	0	7
Bricks	21	11	9	1
Cement	22	12	8	2
Building Materials	37	30	3	4
Sand	29	16	10	3
Aggregate	39	8	15	16
Bread-Cakes	23	22	0	1
Fruit-Vegetables	15	7	5	3
Timber	11	8	2	1
Furniture	33	32	0	1
Explosives	3	1	1	1
Water	11	3	4	4
Stationery	1	1	0	0
Coal	6	5	1	0
Milk Vessels	6	6	0	0
Miscellaneous	53	46	3	4
Milk	4	2	1	1
Mohair	6	6	0	0
<b>TOTAL</b>	<b>551</b>	<b>336</b>	<b>115</b>	<b>100</b>

## 5.0

### TRAFFIC ANALYSIS

Traffic counts were undertaken in conjunction with all the weighings of heavy vehicles. The results of the counts are shown in Appendix 2 for all sites classified by time period and vehicle type.

The Feasibility Study for the Southern Perimeter included a projection of traffic on the sections under design. It was a part of this study to review these traffic projections in the light of newer survey data. The traffic counts confirm the previous findings in 1970, 1973 and 1977, that the traffic density is highest at Mohales Hoek and holds up to Mount Morosi and then drops off radically reflecting the poor condition of the road.

The Feasibility Report uses annual growth rates as shown in Table 5.1.

TABLE 5.1 TRAFFIC GROWTH RATES

	1978-87	1988-99
Light Vehicles	14%	12%
Buses	10%	8%
Trucks	12%	10%

These rates are said to fall between the actual annual rates experienced between 1973 and 1977 and those projected in the Lesotho Transportation Study, which projected an overall growth rate of only 7 percent for this road.

In addition to the natural growth rates there is likely to be "induced traffic" that is traffic attracted by reason of a new and improved road. In the case of this road those segments which are now subject to closure due to the weather and which at present carry the least traffic can be expected to have relatively higher traffic increases once the road is improved.

The Feasibility Study gives an estimate of induced traffic. This estimate is not justified by any analysis and so no comment can be made on it. However, the Feasibility Study gives a projection by vehicle type for each year to 1999 based on these assumptions. (See Table 5.2)

These projections have been shown graphically in Figure 5.1 together with the PRC Harris counts of 1979. It can be seen that in the case of Site No. 6 - Mohales Hoek the count expanded to ADT falls between the 1977 count and the 1980 estimate.

In the case of Sites 7 and 8 (Quthing and Qachas Nek) the count is higher than the estimate for 1980 for Site 7 and 1983 for Site 8. This would indicate that perhaps the projections of future traffic are rather low. Further examination of the count indicates however, that the number of commercial vehicles is well within the expected range and the difference occurs in the number of light

Road Segment	1977	1980	1981	1982	1983	1984	1985	1986	1987	1988	1989	1990	1991	1992	1993	1994	1995	1996	1997	1998	1999	
Type of Vehicle																						
1. Mohale's Hoek/ Makhaleng Junction	LIGHT	175	259	326	367	414	468	530	600	679	757	844	941	1051	1173	1310	1464	1636	1829	2045	2287	2558
2. Makhaleng Junction/ Quthing	LIGHT	95	141	185	208	234	263	296	334	377	419	467	520	579	646	720	804	897	1002	1119	1450	1397
3. Quthing/Mt. Moorosi	LIGHT	51	76	116	128	142	158	175	196	219	242	267	296	328	363	403	448	498	554	617	688	767
4. Mt. Moorosi/Sekakes	LIGHT	16	24	27	59	63	68	74	80	87	94	102	111	121	132	145	158	174	192	212	234	288
5. Sekakes/Mpiti	LIGHT	29	43	49	84	92	99	109	121	134	146	160	176	194	214	236	262	290	321	356	395	440
6. Mpiti/Qacha's Nek	LIGHT	63	93	106	149	164	186	206	233	262	290	321	356	396	440	489	544	606	676	753	840	938
Type of Vehicle																						
1. Mohale's Hoek/ Makhaleng Junction	BUS	42	56	62	69	75	83	91	100	110	119	128	137	149	161	174	188	203	219	236	255	275
2. Makhaleng Junction/ Quthing	BUS	11	15	18	20	21	23	24	26	28	30	32	35	37	40	42	45	49	52	56	60	64
3. Quthing/Mt. Moorosi	BUS	6	8	11	12	13	14	15	16	18	19	20	22	23	25	27	29	31	33	36	38	41
4. Mt. Moorosi/Sekakes	BUS	6	8	9	13	14	15	16	17	19	20	21	23	24	26	28	30	32	34	37	39	42
5. Sekakes/Mphiti	BUS	4	5	6	9	4	11	12	12	13	14	15	16	17	18	19	21	22	24	25	27	29
6. Mpiti/Qacha's Nek	BUS	5	7	7	11	12	13	14	15	16	17	18	19	21	22	24	25	27	29	31	33	36
Type of Vehicle																						
1. Mohale's Hoek/ Makhaleng Junction	TRUCK	82	115	143	159	176	195	217	241	269	294	322	353	387	424	465	510	560	614	675	741	813
2. Makhaleng Junction/ Quthing	TRUCK	35	49	69	76	83	91	101	111	123	134	146	159	173	189	207	226	247	270	296	324	355
3. Quthing/Mt. Moorosi	TRUCK	27	38	56	62	67	74	81	89	98	106	115	126	137	149	163	177	194	212	232	253	277
4. Mt. Moorosi/Sekakes	TRUCK	4	6	7	22	23	24	25	26	27	29	30	32	33	35	37	39	42	44	47	51	55
5. Sekakes/Mphiti	TRUCK	17	24	27	45	49	53	57	62	68	73	79	85	92	100	109	118	128	137	151	166	181
6. Mpiti/Qacha's Nek	TRUCK	30	42	47	68	74	81	89	98	108	117	128	139	151	165	180	197	215	235	257	281	307
Type of Vehicle																						
<b>TOTALS</b>																						
1. Mohale's Hoek/ Makhaleng Junction	TOTALS	299	430	531	595	665	746	838	941	1058	1170	1294	1431	1587	1758	1949	2162	2399	2662	2956	3283	3646
2. Makhaleng Junction/ Quthing	TOTALS	141	205	272	304	338	377	421	471	528	583	645	714	789	875	969	1075	1193	1324	1471	1634	1816
3. Quthing/Mt. Moorosi	TOTALS	84	122	183	202	222	246	271	301	335	367	402	444	488	537	593	654	723	799	885	979	1085
4. Mt. Moorosi/Sekakes	TOTALS	26	38	42	94	100	107	115	123	133	143	153	166	178	193	210	227	248	270	296	324	385
5. Sekakes/Mphiti	TOTALS	50	72	82	138	151	163	178	195	215	233	254	277	303	332	364	401	440	482	532	588	650
6. Mpiti/Qacha's Nek	TOTALS	98	142	160	228	250	280	309	346	386	424	467	514	568	627	693	766	848	940	1041	1157	1281

TRAFFIC PROJECTIONS MOHALE'S HOEK - QACHA'S NEK

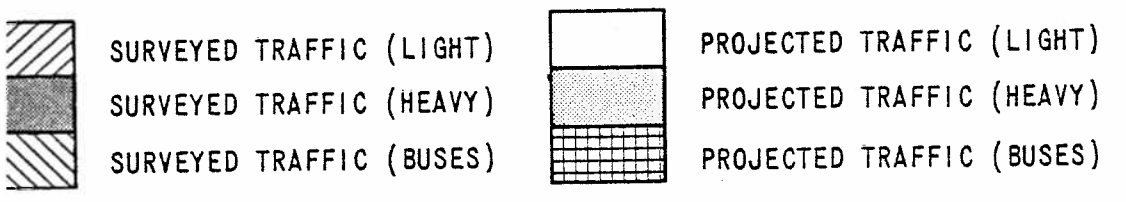
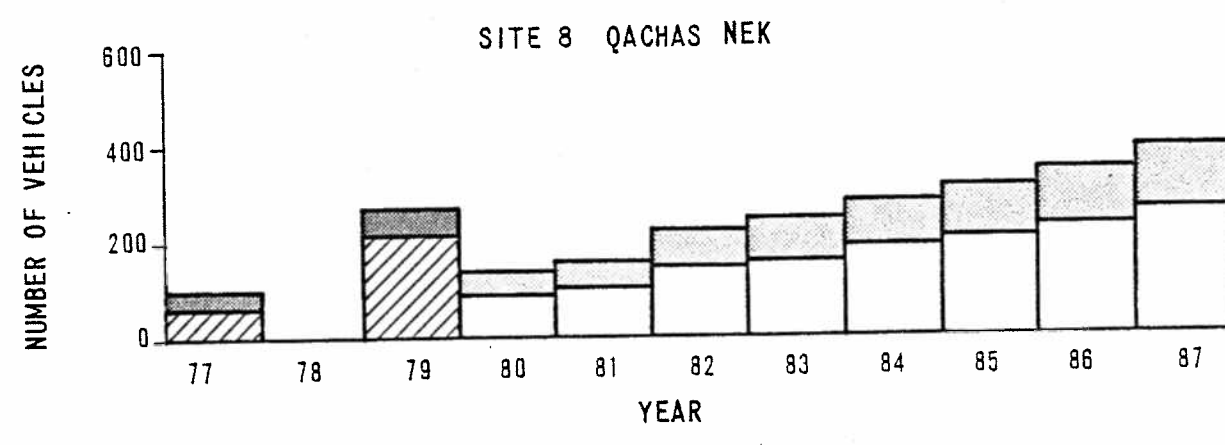
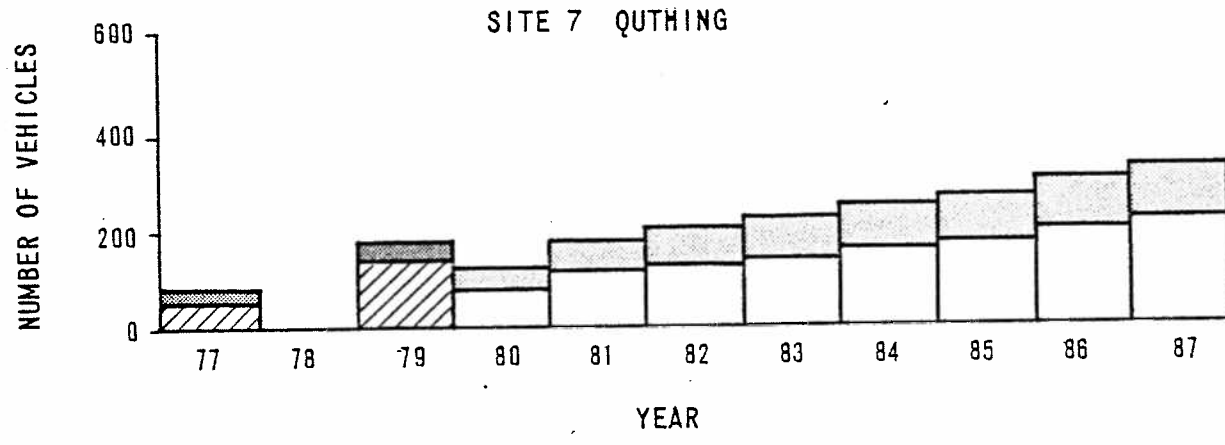
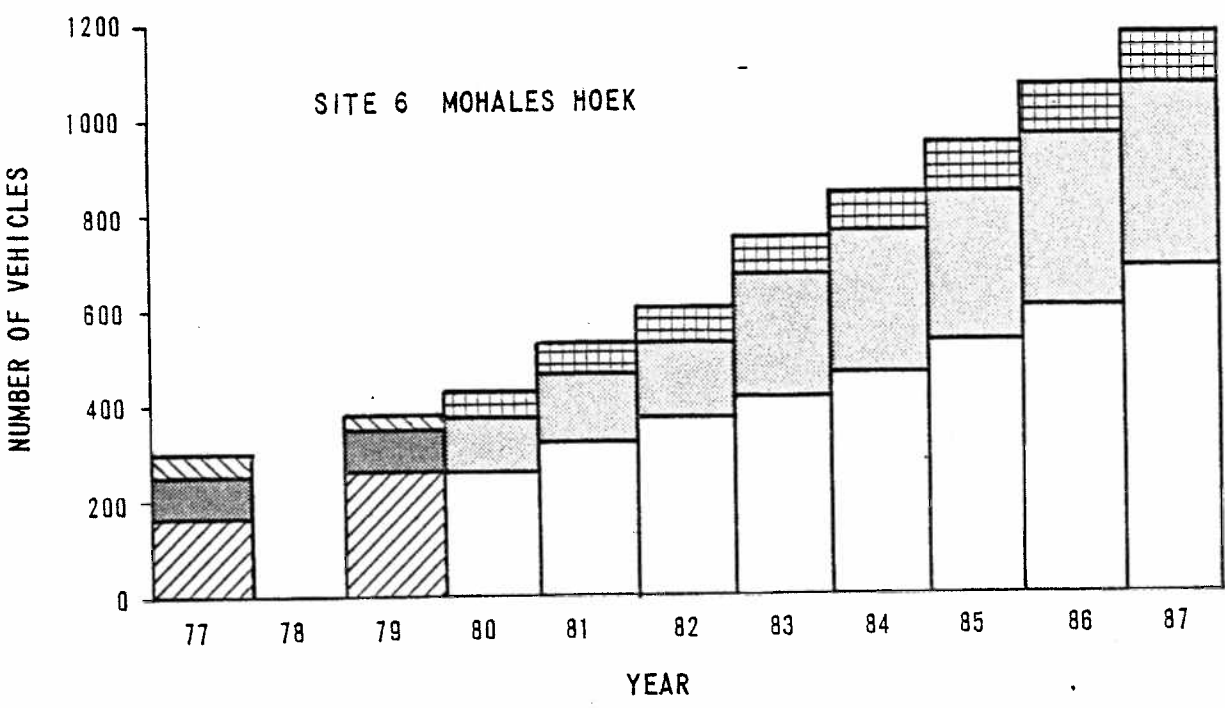

TRAFFIC VOLUMES AND FORECASTS

FIGURE 5.1

vehicles. In view of the fact that the counts were undertaken during the dry season when the road was to be open to light vehicles this difference is not surprising. Also, one must remember that the these traffic flows of the area of 200-300 AADT can be affected significantly by any unusual occurrence in the neighborhood, and so predictions based on such counts must be used with caution.

In view of the foregoing it is recommended that the projections for truck traffic given in the Feasibility Study should be used for the design of the pavement and that regular manual classified traffic counts be undertaken at at least 3 points along the road to determine seasonal variations in traffic.

These traffic volumes are so low that they are well within the capacity of a single truck road at present and are unlikely to exceed this capacity at any time during the projected life of the road, therefore any inaccuracies in the projection of the flows of light traffic are of academic interest only.

## 6.0

### ORIGIN - DESTINATION SURVEY

Commercial vehicle origins and destinations were collected at the time each vehicle was weighed. The table of origins and destinations is shown as Table 6.1 (Please note that the zone codes are shown in Appendix 2).

The locations of survey stations were such that some trips could be intercepted more than once, e.g. a trip from Maseru to Mofokeng would pass through two interview stations, at Maseru and at Mafeteng. Thus the total number of trips from Maseru to Mofokeng should be divided by 2. The factors for all origins and destinations are shown in Table 6.2 except for those where no trips were recorded. In this case an asterisk is shown in Table 6.2.

Table 6.3 gives the final origin-destination matrix, calculated by dividing the values in Table 6.1 by those in Table 6.2. All fractional values were rounded to the next highest integer.

It is a matter of interest that only 2 trips were recorded which had both their origin and destination in the RSA.

DESTINATION

ORIGIN	1	2	3	4	5	6	7	8	9	10	11	12	13	14	20	30	TOTAL
1	0	15	0	11	1	0	0	0	0	0	0	7	0	0	0	0	34
2	12	17	7	26	6	4	0	0	2	8	1	58	1	2	1	0	145
3	1	9	0	29	3	1	1	0	0	2	1	11	3	0	0	0	61
4	14	36	37	158	18	5	13	4	6	19	33	6	1	0	0	6	356
5	1	5	0	19	32	8	1	0	0	13	0	0	0	0	0	1	80
6	0	0	0	2	11	16	9	0	0	1	0	0	0	6	0	2	47
7	0	1	0	9	1	3	13	3	0	5	0	0	0	4	0	0	39
8	0	0	0	1	0	1	1	33	0	0	0	0	0	0	4	0	40
9	0	1	0	2	0	0	0	0	0	0	0	4	0	0	0	0	7
10	0	5	2	19	16	4	8	0	0	1	0	0	0	0	0	0	55
11	0	0	4	26	0	0	0	0	0	0	0	0	0	0	0	0	30
12	8	77	10	22	1	1	0	0	3	0	0	0	0	1	0	0	123
13	1	3	2	1	0	0	0	0	1	0	0	0	0	0	0	0	8
14	0	0	0	0	0	7	4	0	0	0	0	0	0	0	0	0	11
20	0	0	0	0	0	0	0	2	0	0	0	0	0	0	0	0	2
30	1	4	0	8	1	3	3	0	0	0	0	0	0	0	0	0	20
TOTAL	38	173	62	333	90	53	53	42	12	49	35	86	5	13	5	9	1058

TABLE 6.1

ORIGIN - DESTINATION MATRIX AS SURVEYED

DESTINATION

ORIGIN	1	2	3	4	5	6	7	8	9	10	11	12	13	14	20	30
1	1	1	*	4	5	*	*	*	*	*	*	2	*	*	*	*
2	1	1	2	3	4	5	*	*	1	1	1	1	1	1	1	*
3	3	1	1	1	2	3	4	*	*	1	2	2	1	*	*	*
4	4	3	2	1	1	2	3	5	2	1	1	1	1	*	*	1
5	4	3	2	1	1	1	2	*	*	1	*	*	*	*	8	1
6	*	*	*	2	1	1	1	*	*	1	*	*	*	1	*	1
7	*	6	*	3	2	1	1	2	*	1	*	*	*	1	*	*
8	*	*	*	5	*	3	2	1	*	*	*	*	*	*	1	*
9	*	1	*	1	*	*	*	*	1	*	*	2	*	*	*	*
10	*	1	1	1	1	1	1	*	*	1	*	*	*	*	*	*
11	*	*	2	1	*	*	*	*	*	*	1	*	*	*	*	*
12	2	1	2	1	2	*	*	1	*	*	*	1	*	5	*	*
13	1	1	1	1	*	*	*	*	1	*	*	*	1	*	*	*
14	*	*	*	*	*	1	1	*	*	*	*	*	*	1	*	*
20	*	*	*	*	*	*	*	1	*	*	*	*	*	*	1	*
30	1	1	*	1	1	1	1	*	*	*	*	*	*	*	*	1

TABLE 6.2

ORIGIN - DESTINATION CORRECTION MATRIX

DESTINATION

ORIGIN	1	2	3	4	5	6	7	8	9	10	11	12	13	14	20	30	TOTAL
1	0	15	0	3	1	0	0	0	0	0	0	4	0	0	0	0	23
2	12	17	4	9	2	1	0	0	2	8	1	58	1	2	1	0	118
3	1	5	0	29	2	1	1	0	0	2	1	6	3	0	0	0	51
4	4	12	19	158	18	2	5	1	3	19	33	6	1	0	0	6	287
5	1	2	0	19	32	8	1	0	0	13	0	0	0	0	0	1	77
6	0	0	0	1	11	16	9	0	0	1	0	0	0	6	0	2	46
7	0	1	0	3	1	3	13	1	0	5	0	0	0	4	0	0	31
8	0	0	0	1	0	1	1	33	0	0	0	0	0	0	4	0	40
9	0	1	0	2	0	0	0	0	0	0	0	2	0	0	0	0	5
10	0	5	2	19	16	4	8	0	0	1	0	0	0	0	0	0	55
11	0	0	2	26	0	0	0	0	0	0	0	0	0	0	0	0	28
12	4	77	5	22	1	1	0	0	3	0	0	0	0	1	0	0	114
13	1	3	2	1	0	0	0	0	1	0	0	0	0	0	0	0	8
14	0	0	0	0	0	7	4	0	0	0	0	0	0	0	0	0	11
20	0	0	0	0	0	0	0	2	0	0	0	0	0	0	0	0	2
30	1	4	0	8	1	3	3	0	0	0	0	0	0	0	0	0	20
TOTAL	24	142	34	301	85	47	45	37	9	49	35	76	5	13	5	9	916

TABLE 6.3

ORIGIN - DESTINATION MATRIX CORRECTED

APPENDIX I

# KINGDOM OF LESOTHO VEHICLE WEIGHT SURVEY

STATION	DAY	DATE	TIME	DIR <sup>o</sup>	MAKE	MODEL
YEAR	OCC.	REG. NO.	T.	V.	ORIGIN	DESTINATION
OWNER				GOODS CARRIED		

<u>TRUCK TYPE</u> (Circle no.) 1 Single unit 2 Articulated 3 Truck + trailer 4 Artic. tractor 5 Special (specify) -----	<u>SIZE OF LOAD</u> (Circle no.) 1 Empty 2 $\frac{1}{4}$ Full 3 $\frac{1}{2}$ Full 4 $\frac{3}{4}$ Full 5 Full 6 Overloaded
---	---

**AXLES**

Axle No.	1	2	3	4	5	6
Left Wt.						
Right Wt.						
No. of Tyres						

**VEHICLE MEASUREMENTS—METRES** (See reverse)

L1 \_\_\_\_\_ Load Platforms

L2 \_\_\_\_\_

L3 \_\_\_\_\_

L4 \_\_\_\_\_

L5 \_\_\_\_\_

L6 \_\_\_\_\_

L7 \_\_\_\_\_

L8 \_\_\_\_\_

L9 \_\_\_\_\_

	Truck	Trailer
Length		
Width		
Height		

Surveyor \_\_\_\_\_

Coder \_\_\_\_\_

Checked by \_\_\_\_\_

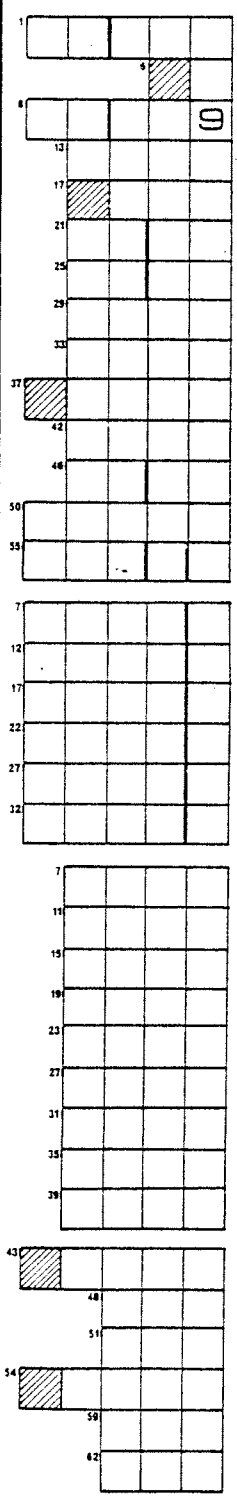

VEHICLE MEASUREMENTS

1. SINGLE UNIT

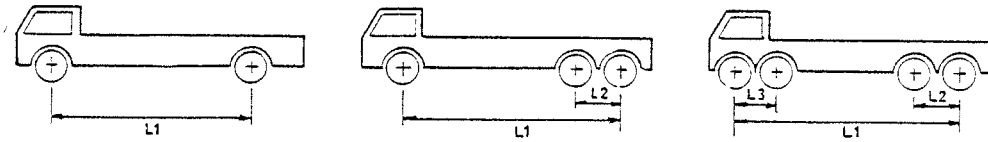

2. ARTICULATED

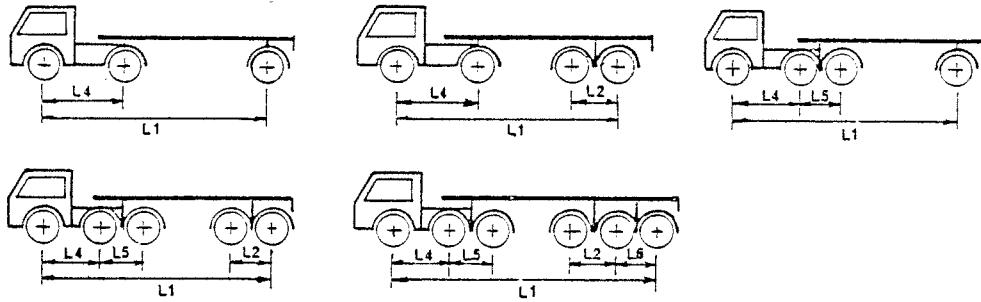

3. TRUCK + TRAILER

For the towing vehicle use length codes as shown in (1) above.



L9 = Total wheelbase of combination

TRUCK MAKER CODES

AEC	01	International Harvester	20
Albion	02	Lancia	21
Alfa Romeo	03	Leyland	22
Bedford	04	Mack	23
Berliet	05	Magirus - Deutz	24
Büssing	06	Man	25
Chrysler (Europe)	07	Mercedes	26
Chrysler (US)	08	Motor Iberica	27
Daf	09	OM	28
Dennis	10	Renault	29
Dodge	11	Saab Scania	30
ERF	12	Saviem	31
Enasa	13	Seddon Atkinson	32
Fiat	14	Scammel	33
Foden	15	Sofim	34
Ford	16	Steyr - Daimler - Puch	35
Freightliner	17	Unic	36
Guy	18	Volvo	37
Hanomag-Herschel	19	VW	38

## MANUAL CLASSIFIED COUNT OF VEHICLES

LOCATION	STATION	DATE	DIRECTION	TIME PERIOD																	
<b>Cars</b>																					
1	2	3	4	5	6	7	8	9	10	11	12	13	14	15	16	17	18	19	20		
21	22	23	24	25	26	27	28	29	30	31	32	33	34	35	36	37	38	39	40		
41	42	43	44	45	46	47	48	49	50	51	52	53	54	55	56	57	58	59	60		
61	62	63	64	65	66	67	68	69	70	71	72	73	74	75	76	77	78	79	80		
81	82	83	84	85	86	87	88	89	90	91	92	93	94	95	96	97	98				
<b>Combis</b>																					
1	2	3	4	5	6	7	8	9	10	11	12	13	14	15	16	17	18	19	20		
21	22	23	24	25	26	27	28	29	30	31	32	33	34	35	36	37	38	39			
<b>Landrovers</b>																					
1	2	3	4	5	6	7	8	9	10	11	12	13	14	15	16	17	18	19	20		
21	22	23	24	25	26	27	28	29	30	31	32	33	34	35	36	37	38	39			
<b>Pick-ups + light vans</b>																					
1	2	3	4	5	6	7	8	9	10	11	12	13	14	15	16	17	18	19	20		
21	22	23	24	25	26	27	28	29	30	31	32	33	34	35	36	37	38	39			
<b>Trucks - single unit</b>																					
1	2	3	4	5	6	7	8	9	10	11	12	13	14	15	16	17	18	19	20		
21	22	23	24	25	26	27	28	29	30	31	32	33	34	35	36	37	38	39			
<b>Trucks - articulated</b>																					
1	2	3	4	5	6	7	8	9	10	11	12	13	14	15	16	17	18	19	20		
21	22	23	24	25	26	27	28	29	30	31	32	33	34	35	36	37	38	39			
<b>Trucks + trailers</b>																					
1	2	3	4	5	6	7	8	9	10	11	12	13	14	15	16	17	18	19	20		
21	22	23	24	25	26	27	28	29	30	31	32	33	34	35	36	37	38	39			
<b>Buses</b>																					
1	2	3	4	5	6	7	8	9	10	11	12	13	14	15	16	17	18	19	20		
21	22	23	24	25	26	27	28	29	30	31	32	33	34	35	36	37	38	39			
<b>Taxis</b>																					
1	2	3	4	5	6	7	8	9	10	11	12	13	14	15	16	17	18	19	20		
21	22	23	24	25	26	27	28	29	30	31	32	33	34	35	36	37	38	39			
<b>Other</b>																					
1	2	3	4	5	6	7	8	9	10	11	12	13	14	15	16	17	18	19	20		
21	22	23	24	25	26	27	28	29	30	31	32	33	34	35	36	37	38	39			

APPENDIX 2

LESOTHO VEHICLE WEIGHT SURVEY - CODING SCHEME

CARD 1

<u>Field No.</u>	<u>Cols.</u>	<u>Desc.</u>	<u>Range</u>	<u>Type</u>
1	1-2	Station No.	01-11	N
2	3-5	Serial No.	001-257	NB
3	6			B
4	7	Day	1-5	N
5	8-9	Day	3-7	NB
			14-16	NB
			19-20	NB
			22-23	NB
			26-27	NB
			29	NB
6	10-11	Month	11-12	N
7	12	Year	9	N
8	13-14	Time Hour	06-17	N
9	15-16	Time Min.	01-59	N
10	17			B
11	18-20	DIRN	0	NB
			90	NB
			180	NB
			270	NB
12	21-22	Make	01-47	N
13	23-26	Model		A
14	27-28	Occ	01-30	N
15	29-36	Reg No.		A
16	37			B
17	38-41	T/10	0-9999	X
18	42-45	V/10	0-9999	X
19	46-47	Origin	01-14	N
			20,30,40, 50	N
20	48-49	Destin	"As Origin"	
21	50-51			B
22	52-54	Owner	01,10,100	
			200,300	NB
23	55	Package	1-4	X
24	56-57	Load Type	01-29	X
25	58	Truck Type	1-5	N
26	59	Size	1-6	N

CARD 2

<u>Field No.</u>	<u>Cols. as shown</u>	<u>New Code</u>	<u>Desc.</u>	<u>Range</u>	<u>Type</u>
27	7-10	7-11	Axle 1 Wt.	700-20000	NB
28	11	12	Tyres	2	N
29	12-15	13-17	Axle 2 Wt.	700-20000	NB
30	16	18	Tyres	2,4	N
31	17-20	19-23	Axle 3 Wt.	10000-20000	X
32	21	24	Tyres	2,4	X
33	22-25	25-29	Axle 4 Wt.	10000-20000	X
34	26	30	Tyres	2,4	X
35	27-30	31-35	Axles 5 Wt.	10000-20000	X
36	31	36	Tyres	2,4	X
37	32-34	37-41	Axle 6 Wt.	10000-20000	X
38	36	42	Tyres	2,4	X

CARD 3

39	7-10		L1	300-1800	NB
40	11-14		L2	120-150	X
41	15-18		L3	120-150	X
42	19-22		L4	200-4--	X
43	23-26		L5	120-150	X
44	27-30		L6	120-150	X
45	31-34		L7	300-1800	X
46	35-38		L8	120-150	X
47	39-42		L9	1000-2000	X
48	43				B
49	44-47		Length	200-1000	X
50	48-50		Width	150-260	X
51	51-53		Height	0-350	X
52	54				B
53	55-59		Length	200-1000	X
54	59-61		Width	150-260	X
55	62-64		Height	0-350	X

## Zone Codes

Butha Buthe	01
Leribe	02
Berea	03
Maseru	04
Mafeteng	05
Mohales Hoek	06
Quthing	07
Qachas Nek	08
Mokhotlong	09
O.F.S.	10
Ladybrand	11
Ficksburg	12
Clocolan	13
Zastron	14
Transkei	20
Transvaal	30
Vitwatersrand	40
Cape	50

Load Type Codes

Maize	01
Live Animals	02
Meat	03
Other Cereals	04
Flour	05
Provisions	06
Fertilizer	07
Oil Products	08
Soft Drinks	09
Machinery	10
Bricks	11
Cement	12
Building Materials	13
Sand	14
Aggregate/Crushed Stone	15
Bread and Cakes	16
Booze	17
Fruit and Vegetables	18
Wood/Timber	19
Furniture	20
Explosives	21
Water Carrier	22
Stationary	23
Coal	24

Milk Vessels	25
Miscellaneous	26
Milk	27
Mohair	28
<u>Owner Codes</u>	
Government	01
Sasko	02
Frasers	03
Lesotho Milling	04
Nqoko	05
<u>Package Codes</u>	
Boxes	1
Bags	2
Bulk	3
Vessels/Containers	4
Lesotho Freight	06
Exley	07
Ladybrank Crushers	08
Sunripe Fruit	09
Driver	100
Scribante	10
Other Private	200
South African Government	300

Additional Truck Maker Codes

Toyota	39
Nissan (Datsun)	40
Mazda	41
Isuzu	42
Oshkosh	43
BMW	44
Daihatsu	45
Chevrolet	47
Hino	48

Leyland Model Codes

Boxer	01
Eland	02
Mammoth	03
Comet	04

Station Codes and Date

<u>Station</u>	<u>Code</u>	<u>Date</u>
Maseru Border Post	01	14/11, 15/11, 16/11
Maseru Khubetsoana	02	19/11
Maseru Masianokeng	03	20/11, 7/12
Mafeteng Phahameng	04	22/11
Mafeteng Border and Van Royen	05	23/11
Mohales Hoek	06	26/11
Quthing	07	27/11
Qachas Nek	08	29/11
TY	09	3/12
Leribe	10	4/12
Maputsoe	11	6/12

NB Serial nos. for Station 3, 7/12/79 start at 200

Direction Codes

North	0
East	90
South	180
West	270

Day Codes

Monday	1
Tuesday	2
Wednesday	3
Thursday	4
Friday	5

## CONSISTENCY CHECKS

N - All numbers - no blanks

NB - All numbers - leading blanks permitted

A - Any Alpha numeric or blank

X - All numeric or blank fields

B - Must be blank

If Field 17 NE Blank and Field 18 NE Blank, Field 18 must be at Field 17

If Field 24 EQ O, Field 26 EQ 1

If Field 25 EQ 2, Fields 48-50 EQ Blank

If Field 25 EQ 3, Field 47 NE Blank

If Field 17 NE Blank, (Field 27 + Field 29 + Field 31 + Field 33 + Field 35 + Field 37)

GE (Field 17 \* 10)

If Field 25 EQ 2, Field 31 NE Blank

If Field 25 EQ 3, Field 31 and Field 33 NE Blank

If Field 31 NE Blank, Field 32 NE Blank

If Field 33 NE Blank, Field 34 NE Blank

If Field 35 NE Blank, Field 36 NE Blank

If Field 37 NE Blank, Field 37 NE Blank

APPENDIX 3

LESOTHO VEHICLE WEIGHT SURVEY

ANALYSIS OF TRAFFIC COUNTS

STATION NO. 1  
 LOCATION: MASERU BORDER POST

DATE: 14/11/79  
 DIRECTION: EAST

HALF HOUR BEGINNING	CARS	COMBIS	LAND MOVES	PICKUPS	SINGLE UNIT	ARTICULATED	TRUCK + TRAILERS	BUSES	TAXIS	OTHER	TOTAL TRUCKS	TOTAL VEHICLES
600	2	0	0	6	2	0	0	0	0	0	2	10
630	6	0	0	9	5	1	0	0	0	0	6	21
700	9	1	0	13	4	0	0	0	0	0	4	27
730	24	0	0	8	1	1	0	0	0	0	2	34
800	14	0	0	9	4	3	0	0	0	0	7	30
830	8	1	0	10	1	0	0	0	0	0	1	20
900	8	1	1	2	1	0	0	0	0	0	1	13
930	6	1	1	1	3	1	0	0	0	0	4	13
1000	14	2	1	9	2	0	0	0	0	0	2	28
1030	10	2	0	6	1	0	0	0	0	0	1	19
1100	10	2	1	2	3	1	0	0	0	0	4	19
1130	17	1	1	4	7	0	0	0	0	0	7	30
1200	14	1	2	5	0	0	0	0	0	0	0	22
1230	14	1	2	5	1	0	0	0	0	0	1	23
1300	9	2	1	0	0	0	1	0	0	0	1	13
1330	8	0	0	2	1	0	0	0	1	0	1	14
1400	8	0	0	2	0	0	0	0	1	2	0	13
1430	8	3	3	8	4	0	0	0	1	0	4	27
1500	6	0	0	5	2	0	0	0	0	0	2	13
1530	12	0	1	0	1	0	0	0	0	1	1	15
1600	6	1	3	10	3	0	0	0	2	1	3	26
1630	14	2	0	6	1	1	0	0	1	0	2	25
1700	15	3	3	4	1	0	0	0	1	0	1	27
1730	12	2	0	7	0	0	0	0	0	0	0	21
12HR TOTAL	254	26	20	133	48	8	1	0	7	6	57	503
DAY TOTAL	254	26	20	133	48	8	1	0	7	6	57	503

LESOTHO VEHICLE WEIGHT SURVEY

ANALYSIS OF TRAFFIC COUNTS

DATE: 141179  
DIRECTION: WEST

STATION NO. 1  
LOCATION: MASERU BORDER POST

HALF HOUR BEGINNING	CARS	COMBIS	LAND ROVERS	PICKUPS	SINGLE UNIT	ARTICULATED	TRUCK + TRAILERS	BUSES	TAXIS	OTHER	TOTAL TRUCKS	TOTAL VEHICLES
600	3	1	0	2	0	0	0	0	2	0	0	8
630	6	0	0	3	1	0	0	0	3	0	1	13
700	7	4	0	3	0	0	0	0	0	0	0	14
730	9	0	1	10	3	0	1	0	1	1	4	26
800	13	1	1	8	0	0	0	0	1	0	0	24
830	10	3	1	7	0	0	0	0	0	0	0	21
900	13	1	1	8	2	0	0	1	0	0	2	26
930	13	2	1	11	3	0	0	1	0	0	3	30
1000	18	2	0	3	2	0	0	1	0	0	2	26
1030	11	4	0	9	1	0	0	0	0	0	1	25
1100	8	1	2	5	0	0	0	0	1	0	0	17
1130	7	0	0	2	1	0	2	0	1	0	3	13
1200	6	0	1	3	3	0	0	0	0	0	3	13
1230	9	1	1	4	4	0	0	0	0	0	4	19
1300	5	2	0	1	2	0	0	0	0	0	2	10
1330	3	1	0	0	1	0	0	0	0	0	1	5
1400	7	0	0	1	1	0	0	1	0	0	1	10
1430	9	0	4	0	5	3	1	0	0	0	9	22
1500	8	3	0	3	2	0	0	0	0	0	2	16
1530	11	0	0	6	6	0	0	0	0	0	6	23
1600	9	0	0	8	1	1	0	0	1	0	2	20
1630	15	0	0	13	2	0	0	0	0	0	2	30
1700	18	1	2	11	3	1	1	0	0	0	5	37
1730	10	1	0	11	0	1	1	0	0	0	2	24
12HR TOTAL	228	28	15	132	43	6	6	3	10	1	55	472
DAY TOTAL	228	28	15	132	43	6	6	3	10	1	55	472

LESOTHO VEHICLE WEIGHT SURVEY

ANALYSIS OF TRAFFIC COUNTS

STATION NO. 1  
LOCATION: MASEKU BORDER POST

DATE: 15/11/79  
DIRECTION: EAST

HALF HOUR BEGINNING	CARS	COMBIS	LAND MOVERS	PICKUPS	SINGLE UNIT	ARTICULATED	TRUCK + TRAILERS	BUSES	TAXIS	OTHER	TOTAL TRUCKS	TOTAL VEHICLES
600	4	0	0	1	5	0	0	0	0	0	5	10
630	5	0	0	3	5	0	1	0	0	0	6	14
700	5	0	0	10	0	0	1	0	0	0	1	16
730	26	2	0	12	0	1	0	0	0	0	1	41
800	7	0	0	5	0	3	1	0	0	1	4	17
830	9	0	1	5	0	1	0	0	0	0	1	16
900	8	1	0	6	0	0	0	0	0	0	0	15
930	12	2	0	9	2	2	0	0	0	0	4	27
1000	10	1	2	8	2	1	0	0	1	0	3	25
1030	11	1	1	9	2	0	0	1	0	0	2	25
1100	19	1	2	7	2	0	1	1	0	0	3	33
1130	8	0	3	0	2	1	0	0	0	1	3	15
1200	11	0	0	2	1	0	0	0	4	0	1	18
1230	13	0	0	7	0	0	1	0	2	0	1	23
1300	1	1	0	3	0	0	0	0	0	0	0	5
1330	7	1	1	10	2	0	0	1	0	0	2	22
1400	4	0	1	4	0	0	0	1	1	0	0	11
1430	7	2	2	2	1	0	1	0	0	0	2	15
1500	5	2	1	3	4	0	0	0	0	0	4	15
1530	7	1	0	2	4	0	1	0	0	0	5	15
1600	7	3	0	4	0	0	0	0	0	0	0	14
1630	14	0	0	8	3	0	0	0	0	0	3	25
1700	21	2	1	8	4	0	0	1	1	0	4	34
1730	2	1	0	1	0	0	0	0	0	0	0	4
1800	7	0	0	3	1	0	0	0	1	0	1	12
1830	9	1	0	2	0	0	0	0	0	0	0	12
1900	11	0	1	5	1	0	0	0	0	0	1	18
1930	6	2	1	0	0	2	0	0	0	0	2	11
2000	2	0	1	0	1	0	0	0	0	0	1	4
2030	1	1	1	1	0	0	0	0	0	0	1	4
2100	4	0	0	0	0	0	1	0	0	0	1	5
2130	3	0	0	3	0	0	0	0	1	0	0	7
12HR TOTAL	223	21	15	129	39	9	7	5	9	2	55	459
DAY TOTAL	266	25	19	143	42	11	8	5	11	2	61	532

LESOTHO VEHICLE WEIGHT SURVEY

ANALYSIS OF TRAFFIC COUNTS

STATION NO. 1  
 LOCATION: MASEKU BORDER POST

DATE: 15/11/79  
 DIRECTION: WEST

HALF HOUR BEGINNING	CARS	COMBIS	LAND ROVERS	PICKUPS	SINGLE UNIT	ARTICULATED	TRUCK + TRAILERS	BUSES	TAXIS	OTHER	TOTAL TRUCKS	TOTAL VEHICLES
600	8	0	0	3	1	0	1	0	0	0	2	13
630	4	0	2	1	0	0	0	0	0	0	0	7
700	7	4	2	5	1	0	1	0	0	0	2	20
730	11	3	0	1	2	0	0	0	1	0	2	18
800	14	1	0	6	1	0	0	0	0	1	1	23
830	17	1	2	8	1	0	0	0	0	0	1	29
900	10	2	0	7	2	0	0	1	0	0	2	22
930	20	4	0	11	0	0	0	1	0	0	0	36
1000	19	1	3	5	3	1	0	0	1	0	4	33
1030	10	0	0	9	0	0	0	1	0	0	0	20
1100	7	1	2	4	1	0	0	0	0	0	1	15
1130	7	2	0	4	1	2	0	0	0	0	3	16
1200	5	0	5	0	2	0	1	0	0	0	3	13
1230	18	1	3	5	2	0	0	0	0	0	0	30
1300	10	1	2	0	0	0	0	0	2	0	0	15
1330	14	1	0	6	4	1	2	0	0	0	3	28
1400	14	0	1	5	2	0	1	0	1	0	3	24
1430	14	2	0	11	0	1	0	2	0	1	1	31
1500	9	1	1	5	0	0	1	0	0	0	1	17
1530	11	5	2	6	0	4	0	0	0	0	4	28
1600	8	0	1	6	1	1	0	0	0	0	2	17
1630	17	0	0	9	0	0	1	0	0	0	1	27
1700	13	0	1	12	2	0	1	0	0	0	3	29
1730	13	0	0	4	0	1	0	0	0	0	1	18
1800	7	0	0	3	0	0	0	0	0	0	0	11
1830	7	0	1	3	0	0	0	0	0	0	1	11
1900	2	0	0	2	1	0	0	0	0	0	1	5
1930	2	1	0	3	1	0	0	0	0	0	3	9
2000	1	0	0	3	0	1	0	0	0	0	1	5
2030	1	2	0	2	0	0	1	0	1	0	1	7
2100	3	0	0	3	1	0	1	0	0	0	2	8
2130	7	0	1	0	2	0	0	0	0	0	2	10
12HR TOTAL	280	30	27	133	26	11	10	5	5	2	47	529
DAY TOTAL	310	33	29	152	32	12	14	5	6	2	58	595

LESOTHO VEHICLE WEIGHT SURVEY

ANALYSIS OF TRAFFIC COUNTS

STATION NO. 1  
 LOCATION: MASERU BORDER POST  
 DATE: 16/11/79  
 DIRECTION: EAST

DATE: 16/11/79  
 DIRECTION: EAST

HALF HOUR BEGINNING	CARS	CUMBIS	LAND MOVES	PICKUPS	SINGLE UNIT	ARTICULATED	TRUCK + TRAILERS	BUSES	TAXIS	OTHER	TOTAL TRUCKS	TOTAL VEHICLES
600	2	1	0	10	2	0	0	0	0	0	2	15
630	6	1	0	9	3	1	1	0	0	0	5	21
700	7	2	0	4	1	0	0	0	0	0	1	14
730	17	1	0	14	0	1	0	0	0	1	1	34
800	6	3	1	3	4	0	0	0	0	0	4	17
830	9	2	1	4	2	0	0	0	0	0	2	18
900	16	3	0	8	2	0	0	0	0	0	2	29
930	5	2	0	5	1	2	0	0	0	0	3	15
1000	11	0	2	5	0	1	0	0	0	0	1	19
1030	8	4	1	0	0	0	0	0	0	0	0	13
1100	5	0	1	5	2	0	0	0	0	0	2	13
1130	8	1	2	0	0	0	0	0	0	0	0	11
1200	4	0	0	4	1	0	0	0	0	0	1	9
1230	4	2	4	2	0	0	1	0	0	0	1	13
1300	4	1	0	2	0	0	0	0	0	0	0	7
1330	7	1	0	5	1	0	0	0	0	0	1	14
1400	3	2	0	4	0	1	0	0	0	0	1	18
1430	10	5	2	7	1	0	0	2	0	6	1	26
1500	6	0	0	0	0	0	1	0	0	0	1	8
1530	8	3	1	5	0	0	0	0	1	0	0	21
1600	8	2	1	3	0	0	0	0	1	3	0	15
1630	12	3	2	6	2	0	0	0	1	0	2	25
1700	14	1	2	10	2	0	0	0	0	0	2	31
1730	13	4	1	10	0	0	1	0	2	0	1	31
1800	11	4	1	6	1	0	0	0	1	0	1	20
1830	20	4	0	5	0	0	1	0	1	0	1	31
1900	7	1	0	6	0	0	0	1	0	0	0	15
1930	8	1	0	8	2	1	0	0	0	0	3	20
2000	8	1	0	4	0	0	0	0	1	0	0	14
2030	8	1	0	4	0	0	1	3	2	9	1	28
2100	4	3	0	5	2	0	0	3	0	10	2	27
2130	11	2	0	9	0	0	0	4	3	2	0	31
15HR TOTAL	193	44	21	125	24	6	4	3	5	12	34	437
DAY TOTAL	270	57	22	172	29	7	6	14	13	33	42	623

LESUTHU VEHICLE WEIGHT SURVEY

ANALYSIS OF TRAFFIC COUNTS

STATION NO. 1  
LOCATION: MASEKU BORDER POST

DATE: 161179  
DIRECTION: WEST

HALF HOUR BEGINNING	CARS	CUMBIS	LAND ROVERS	PICKUPS	SINGLE UNIT	ARTICULATED	TRUCK + TRAILERS	BUSES	TAXIS	OTHER	TOTAL TRUCKS	TOTAL VEHICLES
600	15	1	1	7	0	0	0	1	0	0	0	25
630	3	0	0	5	0	0	0	1	0	0	0	9
700	12	1	2	8	0	1	0	0	0	0	1	24
730	4	2	1	0	1	0	1	0	1	0	2	10
800	14	1	3	6	0	0	0	0	1	0	0	25
830	13	2	2	4	1	0	0	1	1	1	1	25
900	17	1	1	7	1	0	0	0	0	0	1	27
930	14	1	2	0	2	1	1	1	0	0	4	22
1000	22	2	1	8	5	0	0	0	0	1	5	39
1030	14	0	1	0	1	1	0	1	0	0	2	18
1100	9	0	0	4	3	0	0	0	0	1	3	17
1130	8	3	1	0	0	0	0	0	1	1	0	14
1200	4	1	0	2	3	1	0	0	0	0	4	11
1230	3	0	0	5	1	2	0	0	0	0	3	11
1300	19	2	0	4	0	0	0	0	0	0	0	25
1330	8	1	0	4	2	0	0	2	1	0	2	18
1400	19	3	0	9	7	0	0	0	0	0	7	38
1430	5	2	0	9	0	1	0	0	1	0	1	18
1500	10	2	0	4	1	0	0	0	0	0	1	17
1530	8	1	2	6	2	0	0	0	2	0	2	21
1600	10	2	1	8	3	0	0	0	0	0	3	24
1630	9	3	8	4	3	0	0	0	1	0	3	28
1700	14	0	2	9	0	0	0	0	0	0	0	25
1730	8	2	3	4	4	0	0	1	0	2	4	24
1800	6	1	0	1	1	0	0	0	0	0	1	9
1830	11	0	0	8	0	0	0	0	0	0	0	19
1900	3	0	0	2	0	0	0	0	0	0	0	5
1930	7	1	1	4	2	0	0	0	0	2	2	17
2000	3	0	0	1	3	0	0	0	0	0	3	7
2030	5	1	2	0	0	0	0	0	0	0	0	8
2100	10	0	0	5	0	0	0	0	0	0	0	15
2130	6	0	2	3	4	0	0	1	0	1	4	17
12HR TOTAL	262	33	31	117	40	7	2	8	9	6	49	515
DAY TOTAL	313	36	36	141	50	7	2	9	9	9	59	612

LESOTHO VEHICLE WEIGHT SURVEY

ANALYSIS OF TRAFFIC COUNTS

STATION NO. 2  
 LOCATION: MASERU KHUBETSANO

DATE: 191179  
 DIRECTION: NORTH

HALF HOUR BEGINNING	CARS	COMBIS	LAND ROVERS	PICKUPS	SINGLE UNIT	ARTICULATED	TRUCK + TRAILERS	BUSES	TAXIS	OTHER	TOTAL TRUCKS	TOTAL VEHICLES
600	3	0	0	2	0	0	0	1	6	0	0	12
630	4	2	0	4	1	0	0	0	6	0	1	17
700	3	0	2	6	1	0	0	0	4	0	1	16
730	1	0	1	1	1	0	0	0	3	3	1	10
800	2	1	2	2	1	1	0	1	1	0	2	11
830	9	1	2	9	1	0	0	1	9	8	1	40
900	10	1	7	10	1	0	0	0	5	7	1	41
930	5	0	3	3	1	1	0	0	7	0	2	20
1000	5	1	0	4	2	1	0	0	0	1	3	14
1030	1	3	4	4	2	0	0	0	3	0	2	18
1100	9	1	2	6	2	1	0	1	1	0	3	23
1130	1	1	2	9	4	0	0	3	3	1	4	24
1200	6	3	5	7	4	0	0	2	4	2	4	33
1230	6	4	3	8	3	0	0	2	3	2	3	31
1300	13	4	3	6	3	2	0	2	2	1	5	36
1330	2	0	2	9	2	1	0	0	6	1	3	23
1400	2	0	3	6	1	1	0	0	4	0	2	17
1430	7	1	4	9	2	0	0	0	8	0	0	31
1500	3	2	2	3	3	0	1	0	0	0	4	14
1530	2	1	4	6	4	0	0	0	6	0	4	23
1600	4	0	3	8	3	0	0	0	2	1	3	21
1630	8	0	2	11	5	0	0	1	6	0	5	33
1700	9	1	4	9	3	1	0	0	9	0	4	36
1730	6	1	3	11	1	0	1	1	6	0	2	30
1800	5	1	1	9	1	0	0	0	8	0	1	25
1830	4	0	1	5	1	0	0	0	2	0	3	15
1900	2	0	0	1	0	0	0	0	3	0	0	6
1930	3	1	0	2	0	0	2	0	2	0	2	10
2000	2	0	1	3	1	0	0	0	0	0	1	7
2030	0	0	0	4	0	0	0	1	0	0	0	5
2100	1	0	0	0	0	0	0	1	0	0	0	2
2130	1	2	0	4	0	0	0	1	3	0	0	11
12HR TOTAL	121	28	63	153	51	9	2	16	104	27	62	574
DAY TOTAL	139	32	66	181	54	9	6	19	122	27	69	655

LESOTHO VEHICLE WEIGHT SURVEY

ANALYSIS OF TRAFFIC COUNTS

STATION NO. 2  
LOCATION: MASEKU KHUBETSOANA

DATE: 191179  
DIRECTION: SOUTH

HALF HOUR BEGINNING	CARS	COMBIS	LAND ROVERS	PICKUPS	SINGLE UNIT	ARTICULATED	TRUCK + TRAILERS	BUSES	TAXIS	OTHER	TOTAL TRUCKS	TOTAL VEHICLES
600	4	5	1	7	0	0	0	4	7	2	0	30
630	3	2	3	8	1	0	0	2	8	0	1	27
700	3	2	2	4	1	0	0	2	8	0	1	22
730	12	1	3	13	3	0	0	0	5	0	3	37
800	6	1	1	12	1	0	0	0	3	0	1	24
830	3	2	1	4	2	0	0	0	5	3	2	20
900	1	0	2	6	3	0	0	1	6	2	3	21
930	5	1	3	8	1	0	0	1	2	0	1	21
1000	1	1	2	3	1	1	0	0	2	0	2	11
1030	2	1	1	4	5	1	0	0	3	0	6	17
1100	3	0	0	3	1	1	0	0	2	0	2	10
1130	2	0	0	2	1	0	0	1	2	0	1	8
1200	3	1	0	4	1	2	0	0	5	0	3	16
1230	3	2	2	1	2	1	0	2	4	0	3	17
1300	3	0	2	2	3	1	0	1	1	1	4	14
1330	10	2	0	5	1	1	0	0	3	0	2	22
1400	7	1	0	3	3	1	0	0	3	0	4	18
1430	4	0	2	7	3	1	0	0	3	0	4	18
1500	10	1	7	3	3	1	0	3	2	0	4	30
1530	2	1	0	6	4	0	0	0	2	0	4	15
1600	5	3	2	4	4	0	0	1	4	0	0	19
1630	5	0	1	5	2	0	0	0	6	1	2	20
1700	6	0	3	4	1	1	0	0	4	0	2	19
1730	6	0	5	3	1	0	0	1	7	1	1	24
1800	5	0	0	11	2	0	0	0	0	0	2	18
1830	4	2	2	8	4	0	0	1	6	1	4	28
1900	3	2	2	1	0	0	0	0	3	0	0	11
1930	3	0	3	2	0	0	0	0	2	0	0	10
2000	3	0	0	1	0	0	0	0	1	0	0	5
2030	7	0	0	1	0	0	0	1	0	0	0	9
2100	0	0	0	1	0	0	0	1	0	0	0	2
2130	1	0	0	0	1	0	0	0	0	0	1	2
12HR TOTAL	109	27	43	121	44	12	0	19	98	10	56	483
DAY TOTAL	135	31	50	146	51	12	0	22	110	11	63	568

LESOTHO VEHICLE WEIGHT SURVEY

ANALYSIS OF TRAFFIC COUNTS

STATION NO. 3  
LOCATION: MASEKU MASIANOKENG

DATE: 201179  
DIRECTION: NORTH

HALF HOUR BEGINNING	CARS	CUMBIS	LAND ROVERS	PICKUPS	SINGLE UNIT	ARTIC-ULATED	TRUCK + TRAILERS	BUSES	TAXIS	OTHER	TOTAL TRUCKS	TOTAL VEHICLES
600	0	0	0	2	0	0	0	1	7	0	0	10
630	3	2	2	9	3	0	0	1	11	0	3	31
700	6	1	4	4	3	0	0	0	7	1	3	26
730	8	2	3	8	3	0	0	1	5	0	3	30
800	4	0	2	3	3	0	0	0	5	0	3	17
830	7	1	1	6	2	0	1	2	5	1	3	26
900	6	2	3	13	1	0	0	0	7	7	1	39
930	3	3	6	12	3	0	0	1	8	0	3	36
1000	4	2	1	14	1	0	0	1	5	1	1	29
1030	8	2	5	10	3	0	0	1	5	0	3	34
1100	3	3	5	12	2	0	0	2	2	2	2	31
1130	9	1	2	10	3	0	0	1	7	1	3	34
1200	2	0	3	8	2	0	0	1	8	1	2	25
1230	4	3	4	12	1	0	0	1	5	2	1	32
1300	3	2	4	7	6	0	0	0	8	2	6	32
1330	7	1	1	6	3	0	0	1	5	0	3	24
1400	12	2	4	12	2	0	1	0	8	0	3	41
1430	6	1	1	10	3	0	0	0	6	0	3	27
1500	14	1	3	13	1	0	0	2	9	0	1	43
1530	13	2	1	12	4	0	0	1	9	1	4	43
1600	7	2	10	8	5	0	0	2	5	0	5	39
1630	12	0	6	9	6	0	0	1	5	2	6	41
1700	13	1	6	17	5	0	0	2	11	1	5	56
1730	8	1	2	3	0	0	0	0	4	0	0	18
1800	10	0	4	6	5	0	0	0	7	0	5	32
1830	5	2	2	16	7	0	2	3	9	1	9	47
1900	7	0	1	10	6	0	0	1	8	0	6	33
1930	10	2	6	8	0	0	0	0	4	0	0	30
2000	6	0	2	8	1	0	0	0	2	0	1	19
2030	4	0	3	1	0	0	0	0	0	0	0	8
2100	5	1	1	1	1	0	0	0	0	0	1	9
2130	6	0	1	8	0	0	0	0	1	0	0	16
2200	5	2	3	0	0	0	0	0	5	0	0	15
12HR TOTAL	162	35	79	220	65	0	2	22	157	22	67	764
DAY TOTAL	220	42	102	278	85	0	4	26	193	23	69	973

LESOTHO VEHICLE WEIGHT SURVEY

ANALYSIS OF TRAFFIC COUNTS

STATION NO. 3  
 LOCATION: MASERU MASIANKENG

DATE: 201179  
 DIRECTION: SOUTH

HALF HOUR BEGINNING	CARS	CUMBIS	LAND MOVES	PICKUPS	SINGLE UNIT	ARTICULATED	TRUCK + TRAILERS	BUSES	TAXIS	OTHER	TOTAL TRUCKS	TOTAL VEHICLES
600	1	0	0	3	0	0	0	2	2	0	0	8
630	3	0	0	9	1	0	0	2	13	0	1	28
700	10	2	1	16	1	0	0	4	12	0	1	46
730	10	3	3	18	2	0	0	5	11	0	2	52
800	10	0	3	12	3	0	0	5	15	0	3	48
830	6	0	5	7	2	0	0	2	8	2	2	32
900	10	3	6	11	3	0	2	4	14	1	5	54
930	3	0	4	7	3	0	0	2	2	0	3	21
1000	3	4	1	9	7	1	0	3	7	0	8	35
1030	8	0	6	8	10	0	0	8	4	3	10	47
1100	3	1	4	10	8	0	0	1	4	0	8	31
1130	7	0	1	5	9	0	0	1	5	3	9	31
1200	5	0	0	15	4	0	1	5	3	0	4	28
1230	4	0	0	3	6	1	1	0	2	0	8	22
1300	0	0	2	4	3	0	0	5	5	0	3	14
1330	6	3	1	15	5	1	0	4	3	0	6	38
1400	13	4	9	20	9	0	0	8	12	4	9	79
1430	4	1	0	7	7	0	0	1	4	0	7	24
1500	6	2	4	15	4	0	0	3	7	1	4	44
1530	11	2	1	9	5	0	0	4	8	0	5	40
1600	9	1	2	15	0	0	0	4	7	0	0	38
1630	15	1	7	11	5	0	0	3	10	0	5	52
1700	15	2	6	16	2	0	0	4	10	1	2	56
1730	10	0	2	7	0	0	0	4	10	0	0	29
1800	13	1	4	11	2	0	0	4	6	0	2	39
1830	7	2	2	9	0	1	0	3	4	1	1	29
1900	14	2	2	5	2	1	0	0	7	0	1	29
1930	1	1	1	9	1	1	0	0	8	0	3	34
2000	9	1	3	8	0	0	0	0	3	0	2	17
2030	2	1	0	3	0	0	0	0	3	0	0	24
2100	7	0	0	1	0	0	0	0	0	0	0	6
2130	1	0	2	2	0	0	0	0	0	0	0	8
2130	1	0	2	2	0	0	0	0	0	0	0	5
12HK TOTAL	174	29	68	252	99	3	3	80	174	15	105	697
DAY TOTAL	228	37	82	300	104	6	3	84	199	16	113	1059

LESOTHO VEHICLE WEIGHT SURVEY

ANALYSIS OF TRAFFIC COUNTS

STATION NO. 3  
 LOCATION: MASERU MASIANOKENG

DATE: 71279  
 DIRECTION: NORTH

HALF HOUR BEGINNING	CARS	CUMBIS	LAND ROVERS	PICKUPS	SINGLE UNIT	ARTIC-ULATED	TRUCK + TRAILERS	BUSES	TAXIS	OTHER	TOTAL TRUCKS	TOTAL VEHICLES
1600	13	4	6	13	5	1	0	0	9	1	6	52
1630	9	2	2	16	8	0	0	2	12	1	8	52
1700	10	2	6	12	6	1	0	0	7	3	7	47
1730	24	2	9	28	6	1	0	3	21	1	7	95
12HR TOTAL	56	10	23	69	25	3	0	5	49	6	28	246
DAY TOTAL	56	10	23	69	25	3	0	5	49	6	28	246

LESUTHO VEHICLE WEIGHT SURVEY

ANALYSIS OF TRAFFIC COUNTS

DATE: 7/12/79  
DIRECTION: SOUTH

STATION NO. 3  
LOCATION: MASERU MASIANKENG

HALF HOUR BEGINNING	CARS	CURBIS	LAND ROVERS	PICKUPS	SINGLE UNIT	ARTICULATED	TRUCK + TRAILERS	BUSES	TAXIS	OTHER	TOTAL TRUCKS	TOTAL VEHICLES
1600	11	1	5	11	3	0	0	5	9	1	3	46
1630	11	1	4	24	5	0	0	3	6	1	5	55
1700	15	3	3	26	6	0	0	3	19	0	6	75
1730	29	4	6	32	12	1	0	11	18	1	13	114
12HR TOTAL	66	9	18	93	26	1	0	22	52	3	27	290
DAY TOTAL	66	9	18	93	26	1	0	22	52	3	27	290

LESOTHO VEHICLE WEIGHT SURVEY

ANALYSIS OF TRAFFIC COUNTS

STATION NO. 4  
LOCATION: MAFETENG PHAMAMENG

DATE: 22/1/79  
DIRECTION: NORTH

HALF HOUR BEGINNING	CARS	COMBIS	LAND ROVERS	PICKUPS	SINGLE UNIT	ARTIC-ULATED	TRUCK + TRAILERS	BUSES	TAXIS	OTHER	TOTAL TRUCKS	TOTAL VEHICLES
600	0	0	0	2	1	0	0	0	2	0	1	5
630	1	0	1	1	0	0	0	0	2	0	0	5
700	0	0	1	1	2	0	0	0	1	0	2	5
730	1	0	1	0	1	0	0	1	1	1	1	6
800	1	0	1	1	0	0	0	0	1	0	0	4
830	0	0	0	6	0	0	0	2	0	0	0	8
900	3	0	3	3	0	0	0	0	0	0	0	9
930	2	0	0	4	0	0	0	2	0	1	0	9
1000	1	0	0	5	3	0	0	0	1	2	3	12
1030	0	0	1	1	2	1	0	1	0	0	3	6
1100	0	0	0	0	2	0	0	0	0	0	2	2
1130	0	0	1	2	1	0	0	2	0	0	1	6
1200	1	0	0	1	2	0	0	0	2	0	2	6
1230	1	0	0	1	3	0	0	0	0	0	3	5
1300	2	0	1	2	0	0	0	1	0	0	0	6
1330	2	0	1	1	0	0	0	0	1	0	0	5
1400	0	0	1	1	0	0	0	0	1	0	0	5
1430	1	0	0	0	1	0	0	0	0	0	1	2
1500	0	0	1	4	1	1	0	0	1	0	2	8
1530	1	0	1	1	0	0	0	0	2	0	0	4
1600	5	0	2	3	2	0	0	0	0	0	2	12
1630	0	0	0	1	1	0	0	0	0	0	1	2
1700	1	0	2	2	1	0	0	1	1	0	1	8
1730	1	0	0	0	1	0	0	0	0	1	1	3
12HR TOTAL	24	0	18	42	26	2	0	10	15	5	28	142
DAY TOTAL	24	0	18	42	26	2	0	10	15	5	28	142

LESUTHO VEHICLE WEIGHT SURVEY

ANALYSIS OF TRAFFIC COUNTS

STATION NO. 4  
 LOCATION: MAFETENG PHAHAMENG

DATE: 22/11/79  
 DIRECTION: SOUTH

HALF HOUR BEGINNING	CARS	COMBIS	LAND ROVERS	PICKUPS	SINGLE UNIT	ARTICULATED	TRUCK + TRAILERS	BUSES	TAXIS	OTHER	TOTAL TRUCKS	TOTAL VEHICLES
600	0	0	0	1	0	0	0	1	1	0	0	3
630	1	1	1	0	1	0	0	0	0	0	1	4
700	1	0	1	1	2	0	0	0	0	0	2	5
730	0	0	0	1	1	0	0	2	2	1	1	7
800	0	0	0	1	2	0	0	1	0	1	2	5
830	2	1	0	5	0	0	0	0	1	0	0	10
900	2	0	2	1	1	0	0	0	0	0	1	6
930	2	0	1	4	2	0	0	0	1	0	2	10
1000	3	1	1	1	2	0	0	0	0	1	2	9
1030	0	0	0	0	1	0	0	0	0	0	1	1
1100	0	0	1	0	1	0	0	0	2	0	1	4
1130	3	0	1	4	2	1	1	1	0	0	4	13
1200	1	0	2	3	2	0	0	0	0	0	2	8
1230	1	0	1	4	1	0	0	2	0	0	1	9
1300	0	0	0	0	2	0	0	1	0	0	2	3
1330	1	0	0	2	3	0	0	0	1	1	3	8
1400	0	1	0	2	2	0	0	0	1	1	2	7
1430	1	0	0	1	2	0	0	0	1	2	2	8
1500	1	1	1	3	1	0	0	0	3	0	1	10
1530	3	1	0	5	0	0	0	3	1	2	0	15
1600	1	0	0	6	1	0	0	0	1	2	1	11
1630	1	0	2	1	4	0	0	2	2	0	4	12
1700	1	0	1	2	1	0	0	0	2	1	1	8
1730	0	1	2	3	1	0	0	0	2	0	1	9
12HR TOTAL	25	7	18	51	35	1	1	14	21	12	37	185
DAY TOTAL	25	7	18	51	35	1	1	14	21	12	37	185

LESOTHO VEHICLE WEIGHT SURVEY

ANALYSIS OF TRAFFIC COUNTS

STATION NO. 5  
LOCATION: MAFETENG VAN ROYEN

DATE: 23/1/79  
DIRECTION: EAST

HALF HOUR BEGINNING	CARS	CUMBIS	LAND ROVERS	PICKUPS	SINGLE UNIT	ARTICULATED	TRUCK + TRAILERS	BUSES	TAXIS	OTHER	TOTAL TRUCKS	TOTAL VEHICLES
600	0	0	0	0	0	0	0	0	0	0	0	0
630	0	0	1	1	0	0	0	0	0	0	0	2
700	0	1	0	2	0	0	0	0	0	0	0	3
730	0	0	0	1	1	0	0	0	0	0	1	2
800	1	0	0	3	0	0	0	0	0	0	0	4
830	2	0	1	1	1	0	0	0	0	0	1	5
900	2	0	0	2	0	0	0	0	0	0	0	4
930	0	0	0	1	0	0	0	0	0	0	0	1
1000	1	0	0	5	1	0	0	0	0	0	1	7
1030	1	0	0	3	0	0	0	0	0	0	0	4
1100	0	0	0	5	1	0	0	0	0	0	1	6
1130	0	1	0	0	1	0	0	0	0	0	1	2
1200	5	0	0	2	0	0	0	0	0	0	0	7
1230	2	0	0	2	1	0	0	0	0	0	1	5
1300	0	0	0	7	4	0	0	0	0	0	4	11
1330	0	0	0	0	1	0	0	0	0	0	1	1
1400	0	0	0	0	1	0	0	0	0	0	1	1
1430	1	0	0	0	1	0	0	0	0	0	1	1
1500	1	0	0	1	2	0	0	1	0	0	2	5
1530	1	0	0	3	1	0	0	0	0	0	1	5
1600	1	0	0	1	2	0	0	0	0	0	2	4
1630	0	0	0	0	0	0	0	0	0	0	0	1
1700	0	0	4	4	0	0	0	0	0	0	0	4
1730	0	0	0	1	1	0	0	0	0	0	1	2
12HR TOTAL	18	2	6	49	19	0	0	1	0	0	19	95
DAY TOTAL	18	2	6	49	19	0	0	1	0	0	19	95

LESOTHU VEHICLE WEIGHT SURVEY

ANALYSIS OF TRAFFIC COUNTS

STATION NO. 5  
 LOCATION: MAFETENG VAN ROYEN

DATE: 23/1/79  
 DIRECTION: WEST

HALF HOUR BEGINNING	CARS	CUMBIS	LAND ROVERS	PICKUPS	SINGLE UNIT	ARTICULATED	TRUCK + TRAILERS	BUSES	TAXIS	OTHER	TOTAL TRUCKS	TOTAL VEHICLES
600	0	0	0	2	1	0	0	0	0	0	1	3
630	0	0	0	4	1	0	0	1	0	0	1	6
700	0	0	0	2	1	0	0	0	0	0	1	3
730	0	0	0	1	1	0	0	0	0	0	1	2
800	0	0	0	3	2	0	0	0	0	0	2	5
830	0	0	0	1	2	0	0	0	0	0	2	3
900	0	0	0	3	0	0	0	0	0	0	0	3
930	3	1	1	3	2	0	0	0	0	0	2	10
1000	1	0	0	1	0	0	0	0	0	0	0	2
1030	1	0	0	2	2	0	0	0	0	0	2	5
1100	1	0	0	4	0	0	0	0	0	0	0	5
1130	0	0	0	5	0	0	0	0	0	0	0	5
1200	0	0	0	0	0	0	0	0	0	0	0	0
1230	0	0	0	0	1	0	0	0	0	0	1	1
1300	1	0	0	0	1	0	0	0	0	0	1	2
1330	0	0	0	1	0	0	0	0	0	0	0	1
1400	1	0	0	0	0	0	0	0	0	0	0	1
1430	1	0	0	1	0	0	0	0	0	0	1	2
1500	0	0	0	2	1	0	0	0	0	0	1	3
1530	0	1	0	1	1	0	0	0	0	0	1	3
1600	0	0	0	0	0	0	0	0	0	0	0	0
1630	0	0	0	1	0	0	0	0	0	0	0	1
1700	0	0	0	1	0	0	0	0	0	0	0	1
1730	0	0	0	1	0	0	0	0	0	0	0	1
12HR TOTAL	9	2	1	39	16	0	0	1	0	0	16	68
DAY TOTAL	9	2	1	39	16	0	0	1	0	0	16	68

LESOTHO VEHICLE WEIGHT SURVEY

ANALYSIS OF TRAFFIC COUNTS

STATION NO. 6  
 LOCATION: MUHALE'S HOEK

DATE: 26/11/79  
 DIRECTION: NORTH

HALF HOUR BEGINNING	CARS	COMBIS	LAND MOVENS	PICKUPS	SINGLE UNIT	ARTIC-ULATED	TRUCK + TRAILERS	BUSES	TAXIS	OTHER	TOTAL TRUCKS	TOTAL VEHICLES
600	1	0	0	2	0	0	0	0	0	2	0	5
630	0	0	0	1	0	0	1	0	0	3	1	5
700	3	0	0	3	1	0	1	2	0	1	2	11
730	0	0	0	1	4	0	0	0	0	0	4	5
800	1	0	0	2	2	0	0	1	1	0	2	7
830	0	0	1	3	0	0	0	0	0	1	0	5
900	0	0	0	4	2	0	0	2	1	2	2	11
930	1	0	1	0	1	0	0	0	0	0	1	3
1000	0	0	2	4	1	0	0	1	0	0	1	8
1030	2	0	2	3	1	0	0	1	0	0	1	9
1100	0	0	0	2	0	0	0	1	1	0	0	4
1130	0	0	1	2	0	0	0	0	0	1	0	4
1200	0	0	1	1	1	0	0	0	2	0	0	5
1230	2	0	1	0	1	0	0	0	0	0	1	4
1300	1	0	1	3	1	0	0	0	1	1	1	8
1330	1	0	0	4	0	0	0	2	0	1	0	8
1400	2	0	0	1	2	0	0	0	0	1	2	6
1430	1	1	2	2	0	0	0	0	0	0	0	6
1500	1	1	2	2	2	0	0	0	0	0	2	8
1530	0	0	0	3	0	0	0	2	0	0	0	5
1600	1	1	1	4	3	0	0	0	0	0	3	10
1630	2	0	0	1	1	0	0	0	0	5	1	9
1700	0	0	2	5	0	0	0	0	1	1	0	9
1730	1	0	0	2	1	0	0	0	0	0	1	4
12HR TOTAL	20	3	17	55	24	0	2	12	7	19	26	159
DAY TOTAL	20	3	17	55	24	0	2	12	7	19	26	159

LESOTHO VEHICLE WEIGHT SURVEY

ANALYSIS OF TRAFFIC COUNTS

DATE: 26/11/79  
DIRECTION: SOUTH

STATION NO. 6  
LOCATION: MUHALE'S HUEK

HALF HOUR BEGINNING	CARS	CUMBIS	LAND ROVERS	PICKUPS	SINGLE UNIT	ARTICULATED	TRUCK + TRAILERS	BUSES	TAXIS	OTHER	TOTAL TRUCKS	TOTAL VEHICLES
600	0	0	0	0	0	0	0	0	0	0	0	0
630	0	0	0	1	0	0	0	0	0	0	0	1
600	1	0	0	1	1	0	0	0	0	0	1	3
700	2	0	0	1	0	0	0	2	1	0	0	6
730	1	0	0	1	3	0	0	0	0	1	3	6
800	2	0	0	1	0	0	0	0	0	0	0	3
830	0	2	3	4	1	0	0	0	2	2	1	14
900	2	0	1	2	1	0	0	3	0	2	1	11
930	2	0	1	3	1	0	1	0	0	0	4	11
1000	0	0	2	3	3	0	1	0	1	1	2	11
1030	1	0	0	4	2	0	0	0	0	1	2	8
1100	0	0	0	1	0	0	0	0	0	1	0	2
1130	1	0	0	4	0	0	0	1	1	1	0	8
1200	0	0	0	1	0	0	0	1	0	0	0	2
1230	3	0	2	0	1	0	0	0	0	0	1	6
1300	1	0	0	1	1	0	0	2	2	1	1	8
1330	0	0	2	1	3	0	0	0	0	1	3	7
1400	0	0	3	2	0	0	0	2	0	0	0	7
1430	0	0	1	3	1	0	0	0	1	1	1	7
1500	1	0	0	3	1	0	0	0	1	4	1	10
1530	2	0	1	1	1	0	0	1	2	0	1	8
1600	2	0	0	1	2	0	0	0	0	0	2	5
1630	1	0	1	3	3	0	0	0	1	1	3	10
1700	1	0	1	5	1	0	0	1	0	0	1	9
1730	0	1	1	1	0	0	0	0	1	0	0	4
12HR TOTAL	23	3	19	48	26	0	2	13	13	17	28	164
DAY TOTAL	23	3	19	48	26	0	2	13	13	17	28	164

LESOTHO VEHICLE WEIGHT SURVEY

ANALYSIS OF TRAFFIC COUNTS

STATION NO. 7  
LOCATION: MUTHING

DATE: 27/1/79  
DIRECTION: EAST

HALF HOUR BEGINNING	CARS	COMBIS	LAND RUVERS	PICKUPS	SINGLE UNIT	ARTICULATED	TRUCK + TRAILERS	BUSES	TAXIS	OTHER	TOTAL TRUCKS	TOTAL VEHICLES
600	0	1	0	2	0	0	0	0	3	0	0	6
630	0	0	1	3	1	0	0	0	1	0	1	6
700	1	0	1	1	0	0	0	0	0	1	0	4
730	0	0	1	1	4	0	0	0	4	0	4	10
800	1	0	0	0	1	0	0	0	1	0	1	3
830	0	0	0	0	1	0	0	1	0	0	1	2
900	0	0	0	0	0	0	0	1	1	0	0	2
930	0	0	0	3	2	0	0	0	2	0	2	7
1000	0	0	0	2	1	0	0	0	1	0	1	4
1030	0	1	1	0	0	0	0	0	0	0	0	2
1100	0	0	2	0	0	0	0	0	1	1	0	4
1130	0	0	0	0	0	0	0	0	0	0	0	0
1200	0	0	0	1	2	0	0	0	2	0	2	5
1230	1	0	0	1	1	0	0	0	0	0	1	3
1300	0	0	0	0	2	0	0	0	2	0	2	4
1330	0	0	0	0	0	0	0	0	1	1	0	2
1400	0	0	0	1	1	0	0	0	1	0	1	3
1430	0	0	1	1	1	0	0	0	1	0	1	4
1500	0	0	2	2	1	0	0	0	1	0	1	6
1530	0	0	0	2	0	0	0	0	0	0	0	2
1600	0	0	1	0	0	0	0	0	0	0	0	1
1630	0	0	0	0	0	0	0	0	1	0	0	1
1700	0	0	0	0	1	0	0	0	0	0	1	1
1730	0	0	0	0	0	0	0	0	0	0	0	0
12HR TOTAL	3	2	10	20	19	0	0	2	23	3	19	82
DAY TOTAL	3	2	10	20	19	0	0	2	23	3	19	82

LESUTHU VEHICLE WEIGHT SURVEY

ANALYSIS OF TRAFFIC COUNTS

STATION NO. 7 GUTHING DATE: 27/11/79  
 LOCATION: GUTHING DIRECTION: WEST

HALF HOUR BEGINNING	CARS	CUMBIS	LAND ROVERS	PICKUPS	SINGLE UNIT	ARTICULATED	TRUCK + TRAILERS	BUSES	TAXIS	OTHER	TOTAL TRUCKS	TOTAL VEHICLES
600	0	0	1	0	0	0	0	0	1	0	0	2
630	0	0	0	0	0	0	0	0	1	1	0	2
700	0	0	0	1	0	0	0	0	0	0	0	1
730	0	0	0	0	2	0	0	0	0	0	2	2
800	0	0	1	1	2	0	0	0	1	0	2	5
830	0	0	1	0	0	0	0	1	0	0	0	2
900	1	0	0	1	1	0	0	0	0	0	1	3
930	0	0	0	2	1	0	0	0	1	0	1	4
1000	0	0	1	0	0	0	0	0	0	0	0	1
1030	0	0	3	2	1	0	0	0	2	0	1	8
1100	1	1	0	2	0	0	0	0	0	0	0	4
1130	0	0	1	1	0	0	0	2	1	0	0	5
1200	0	0	2	1	2	0	0	2	0	0	2	7
1230	0	0	0	0	0	0	0	0	0	0	0	0
1300	0	0	0	0	2	0	0	0	2	1	2	5
1330	0	0	0	0	2	0	0	0	1	0	2	3
1400	1	0	0	1	0	0	0	0	0	1	0	3
1430	0	0	1	0	0	0	0	0	1	0	0	2
1500	0	0	0	1	0	0	0	0	2	0	0	3
1530	0	0	1	2	0	0	0	0	1	0	0	4
1600	0	0	0	2	0	0	0	0	2	0	0	4
1630	0	0	0	0	0	0	0	0	0	0	0	0
1700	0	0	0	0	2	0	0	0	2	0	2	4
1730	0	0	1	1	3	0	0	0	1	0	3	6
12HR TOTAL	3	1	13	18	18	0	0	5	19	3	18	80
DAY TOTAL	3	1	13	18	18	0	0	5	19	3	18	80

LESOTHO VEHICLE WEIGHT SURVEY  
ANALYSIS OF TRAFFIC COUNTS

STATION NO. 8  
LOCATION: QUACHA'S NEK

DATE: 29/11/79  
DIRECTION: EAST

HALF HOUR BEGINNING	CARS	CUMBIS	LAND ROVERS	PICKUPS	SINGLE UNIT	ARTICULATED	TRUCK + TRAILERS	BUSES	TAXIS	OTHER	TOTAL TRUCKS	TOTAL VEHICLES
600	1	0	0	0	1	0	0	1	0	0	1	3
630	0	0	1	0	0	0	0	0	1	1	0	3
700	0	0	1	0	0	0	0	1	0	0	0	2
730	0	0	2	1	3	0	0	1	0	0	3	7
800	0	0	1	1	1	0	0	0	1	0	1	4
830	0	0	3	2	1	0	0	0	1	0	1	7
900	0	0	2	4	2	0	0	1	1	0	2	9
930	1	0	2	6	1	0	0	2	1	0	1	13
1000	0	0	3	2	1	0	0	0	0	0	1	6
1030	0	0	0	1	1	0	0	0	0	0	1	2
1100	0	0	1	1	1	0	0	0	0	0	1	3
1130	0	0	2	3	1	0	0	0	0	0	1	6
1200	1	0	2	3	1	0	0	0	1	0	1	8
1230	1	0	1	2	1	0	0	0	0	0	1	5
1300	0	0	0	0	0	0	0	0	0	0	0	0
1330	0	0	1	1	1	0	0	0	0	0	1	3
1400	0	0	2	1	0	0	0	0	2	0	0	5
1430	0	0	3	5	0	0	0	1	0	0	0	9
1500	0	0	0	0	2	0	0	0	0	0	2	2
1530	0	0	2	1	0	0	0	0	0	0	0	3
1600	0	0	1	1	1	0	0	0	0	0	1	3
1630	2	1	0	0	1	0	0	0	0	0	1	4
1700	0	0	2	0	3	0	0	0	0	0	3	5
1730	2	0	1	0	0	0	0	1	1	0	0	5
12HR TOTAL	8	1	32	35	23	0	0	8	9	1	23	117
DAY TOTAL	8	1	32	35	23	0	0	8	9	1	23	117

LESUTHU VEHICLE WEIGHT SURVEY

ANALYSIS OF TRAFFIC COUNTS

STATION NO. 8  
 LOCATION: MUACHA'S NEK  
 DATE: 29/11/79  
 DIRECTION: WEST

HALF HOUR BEGINNING	CARS	CUMBIS	LAND ROVERS	PICKUPS	SINGLE UNIT	ARTICULATED	TRUCK + TRAILERS	BUSES	TAXIS	OTHER	TOTAL TRUCKS	TOTAL VEHICLES
600	0	0	0	0	0	0	0	0	0	1	0	1
630	0	0	2	1	0	0	0	1	2	0	0	6
700	0	0	0	0	0	0	0	0	0	0	0	0
730	0	0	0	0	0	0	0	0	0	0	0	0
800	1	0	3	3	0	0	0	0	0	0	0	7
830	0	0	3	1	1	0	0	1	0	0	1	6
900	1	0	2	3	3	0	0	1	0	0	3	8
930	0	0	1	1	3	0	0	1	0	0	3	6
1000	0	0	5	2	1	0	0	0	1	0	1	9
1030	1	0	3	3	1	0	0	0	0	0	1	8
1100	0	0	3	1	1	0	0	0	0	0	1	5
1130	0	0	1	2	0	0	0	0	0	0	0	3
1200	0	0	2	2	1	0	0	0	0	0	0	5
1230	0	0	0	5	1	0	0	1	1	0	1	10
1300	0	0	0	0	1	0	0	0	2	0	1	3
1330	0	0	1	4	0	0	0	0	0	0	0	5
1400	0	0	0	2	1	0	0	0	1	0	1	4
1430	0	0	3	2	0	0	0	0	2	0	0	7
1500	0	0	2	1	0	0	0	0	0	0	0	3
1530	0	0	2	0	1	0	0	0	2	0	1	5
1600	0	0	1	0	1	0	0	0	0	0	1	2
1630	0	0	0	3	1	0	0	2	0	0	1	6
1700	0	0	1	1	1	0	0	0	0	0	1	3
1730	0	0	0	1	1	0	0	1	0	0	1	3
12HR TOTAL	3	0	37	37	19	0	0	7	11	1	19	115
DAY TOTAL	3	0	37	37	19	0	0	7	11	1	19	115

LESOTHO VEHICLE WEIGHT SURVEY

ANALYSIS OF TRAFFIC COUNTS

STATION NO. 9  
LOCATION: T-Y

DATE: 31279  
DIRECTION: NORTH

HALF HOUR BEGINNING	CARS	CUMBIS	LAND ROVERS	PICKUPS	SINGLE UNIT	ARTICULATED TRAILERS	TRUCK + TRAILERS	BUSES	TAXIS	OTHER	TOTAL TRUCKS	TOTAL VEHICLES
600	1	0	0	1	1	0	0	0	8	0	1	11
630	1	0	0	0	0	0	0	0	3	0	0	4
700	3	0	2	2	0	0	0	2	7	0	0	16
730	3	2	0	2	4	0	0	0	3	1	4	15
800	2	0	1	6	2	0	0	1	7	2	2	21
830	2	1	0	4	0	0	0	1	4	0	0	12
900	0	0	0	3	1	0	0	2	7	0	1	13
930	6	2	1	5	1	1	0	0	7	0	2	22
1000	4	0	0	4	0	0	0	0	2	4	0	11
1030	5	1	1	11	1	0	0	0	2	1	1	23
1100	5	3	0	9	0	0	0	0	4	0	1	21
1130	1	0	0	2	3	1	0	0	4	0	0	12
1200	1	0	1	5	2	0	0	1	2	1	4	13
1230	3	0	1	6	1	1	0	0	4	1	2	17
1300	4	0	1	6	2	0	0	0	4	1	2	21
1330	0	1	1	4	3	1	0	2	5	1	4	12
1400	4	0	0	6	0	0	0	0	0	0	0	11
1430	2	0	0	2	1	1	0	0	1	0	2	8
1500	1	2	1	3	1	1	0	0	2	0	2	14
1530	5	1	4	1	2	0	0	1	4	3	2	21
1600	0	0	2	5	4	0	0	1	5	0	4	17
1630	3	1	3	2	3	0	0	1	4	0	3	17
1700	1	1	1	4	1	0	0	1	2	1	1	12
1730	1	0	2	6	5	0	1	1	2	1	6	19
12HR TOTAL	58	15	24	99	39	5	1	14	91	17	45	363
DAY TOTAL	58	15	24	99	39	5	1	14	91	17	45	363

LESOTHO VEHICLE WEIGHT SURVEY

ANALYSIS OF TRAFFIC COUNTS

STATION NO. 9  
 LOCATION: T-Y

DATE: 31279  
 DIRECTION: SOUTH

HALF HOUR BEGINNING	CARS	CUMBIS	LAND ROVERS	PICKUPS	SINGLE UNIT	ARTICULATED	TRUCK + TRAILERS	BUSES	TAXIS	OTHER	TOTAL TRUCKS	TOTAL VEHICLES
600	3	0	0	2	0	0	0	0	0	1	0	6
630	0	0	1	7	0	0	0	0	6	0	0	14
700	5	0	0	7	1	0	0	0	5	0	1	18
730	0	0	0	6	1	0	0	0	4	0	1	11
800	2	0	0	5	0	0	0	0	8	0	0	15
830	1	0	3	7	3	0	0	0	3	0	3	17
900	0	0	0	1	0	0	0	2	1	1	0	5
930	2	0	0	4	2	1	0	1	1	0	3	11
1000	2	1	0	5	2	0	0	0	2	1	2	13
1030	3	3	1	7	1	1	0	0	6	0	2	23
1100	3	0	0	3	2	1	0	1	2	0	3	12
1130	3	0	3	3	1	1	0	1	2	0	2	14
1200	3	0	1	6	1	0	0	0	4	0	1	15
1230	3	0	0	0	0	0	0	0	2	0	0	5
1300	2	1	2	3	2	1	0	0	1	0	3	12
1330	5	1	0	4	5	0	0	0	2	2	5	19
1400	2	1	2	1	3	0	1	0	4	0	4	14
1430	5	3	3	6	3	0	0	3	5	0	3	28
1500	4	0	1	3	2	0	0	1	4	0	2	15
1530	5	0	0	9	1	0	0	1	3	0	1	19
1600	3	0	0	5	0	0	0	0	2	0	0	10
1630	5	1	1	6	0	0	0	2	5	0	0	20
1700	4	2	3	7	3	1	0	0	3	0	4	23
1730	4	2	4	0	1	0	0	0	5	0	1	16
12HR TOTAL	69	15	25	107	34	6	1	13	80	5	41	355
DAY TOTAL	69	15	25	107	34	6	1	13	80	5	41	355

LESOTHO VEHICLE WEIGHT SURVEY

ANALYSIS OF TRAFFIC COUNTS

STATION NO. 10  
LOCATION: LERIBE

DATE: 41279  
DIRECTION: NORTH

HALF HOUR BEGINNING	CARS	COMBIS	LAND ROVERS	PICKUPS	SINGLE UNIT	ARTICULATED	TRUCK + TRAILERS	BUSES	TAXIS	OTHER	TOTAL TRUCKS	TOTAL VEHICLES
600	2	1	1	7	0	0	0	2	0	0	0	13
630	1	0	0	3	1	0	0	0	0	1	1	6
700	0	0	0	1	1	0	0	1	3	0	1	6
730	0	1	0	3	1	0	0	0	1	0	1	6
800	0	0	4	3	2	0	0	1	2	0	2	12
830	0	0	3	4	1	0	0	1	0	0	1	9
900	0	0	1	1	1	0	0	0	0	0	1	3
930	0	0	1	5	2	0	0	1	1	0	2	10
1000	1	0	2	2	2	1	0	0	1	1	3	10
1030	0	0	3	4	2	0	0	1	1	0	2	11
1100	1	0	0	3	2	0	0	4	0	0	2	10
1130	1	0	0	5	1	0	0	1	0	1	1	9
1200	1	1	4	1	1	0	0	1	0	0	1	9
1230	1	0	1	4	1	0	0	0	1	0	1	8
1300	1	0	2	4	2	0	0	1	2	0	2	12
1330	1	1	3	1	1	0	0	0	1	0	1	8
1400	0	1	1	3	3	0	0	0	1	0	3	8
1430	1	0	1	4	0	0	0	4	1	1	0	12
1500	1	1	1	3	1	0	0	0	0	1	1	8
1530	1	0	1	1	1	1	0	1	1	1	2	8
1600	2	1	1	4	2	0	0	1	0	0	2	11
1630	0	0	1	3	3	0	0	1	0	0	3	8
1700	0	2	1	6	3	0	0	2	0	1	3	15
1730	0	1	0	5	2	0	0	1	0	0	2	9
12HR TOTAL	15	10	32	80	36	2	0	24	15	7	38	221
DAY TOTAL	15	10	32	80	36	2	0	24	15	7	38	221

LESOTHO VEHICLE WEIGHT SURVEY

ANALYSIS OF TRAFFIC COUNTS

STATION NO. 10  
LOCATION: LERIBE

DATE: 4/12/79  
DIRECTION: SOUTH

HALF HOUR BEGINNING	CARS	COMBIS	LAND ROVERS	PICKUPS	SINGLE UNIT	ARTICULATED	TRUCK + TRAILERS	BUSES	TAXIS	OTHER	TOTAL TRUCKS	TOTAL VEHICLES
600	0	0	0	2	0	0	0	0	1	0	0	3
630	1	0	0	0	1	0	0	2	4	1	1	9
700	0	0	0	4	1	0	0	0	0	0	1	5
730	0	0	1	1	1	0	0	1	2	1	1	7
800	3	0	1	6	0	0	0	1	0	1	0	12
830	0	0	0	3	3	0	0	3	1	1	3	11
900	2	0	1	6	1	0	0	0	0	1	1	11
930	0	0	0	5	0	0	0	1	2	0	0	8
1000	0	1	2	3	1	0	0	1	0	0	1	8
1030	0	0	1	3	0	0	0	0	1	0	0	5
1100	1	0	1	2	4	0	0	1	3	1	4	13
1130	1	0	0	3	1	0	0	1	0	0	1	6
1200	2	0	0	1	0	0	0	1	1	0	0	5
1230	0	1	3	3	0	0	0	0	1	1	1	9
1300	0	0	0	3	2	0	0	0	0	0	2	6
1330	0	0	1	1	1	0	0	1	0	0	1	4
1400	0	1	1	2	2	0	0	1	0	0	2	7
1430	1	1	1	1	2	0	0	0	1	1	2	8
1500	1	0	0	7	0	0	0	0	1	0	0	9
1530	0	0	0	1	2	0	0	2	0	1	2	6
1600	2	1	0	3	2	0	0	0	0	1	2	9
1630	1	0	0	3	1	1	0	1	4	0	2	11
1700	1	1	2	3	4	0	0	2	4	3	4	20
1730	2	2	4	7	2	0	0	0	1	0	2	18
12HR TOTAL	18	8	19	73	31	1	0	19	27	14	32	210
DAY TOTAL	18	8	19	73	31	1	0	19	27	14	32	210

LESOTHO VEHICLE WEIGHT SURVEY

ANALYSIS OF TRAFFIC COUNTS

STATION NO. 11  
LOCATION: MAPUTSUE

DATE: 61279  
DIRECTION: EAST

HALF HOUR BEGINNING	CAVS	CUMBIS	LAND ROVERS	PICKUPS	SINGLE UNIT	ARTICULATED	TRUCK + TRAILERS	BUSES	TAXIS	OTHER	TOTAL TRUCKS	TOTAL VEHICLES
600	2	1	1	7	0	0	0	0	0	0	0	11
630	2	1	0	2	0	0	0	0	1	0	0	6
700	5	2	0	3	0	0	0	1	0	1	0	12
730	5	2	0	3	1	0	0	0	2	0	1	13
800	4	0	0	3	2	1	1	0	2	1	4	14
830	4	0	1	5	5	0	0	1	0	0	5	16
900	4	0	0	5	4	1	1	0	0	2	6	17
930	5	4	2	12	4	0	1	0	0	1	5	29
1000	3	3	1	14	4	0	0	1	1	0	4	27
1030	5	1	1	9	7	0	1	0	0	1	8	25
1100	4	0	1	5	8	0	0	1	0	1	8	20
1130	4	1	1	4	2	1	1	1	0	5	4	20
1200	2	1	3	6	6	0	0	1	1	3	6	23
1230	6	1	0	12	3	0	1	1	0	1	4	25
1300	1	2	1	8	6	0	1	1	1	0	7	21
1330	5	2	1	9	7	0	1	1	1	4	8	30
1400	3	2	0	5	2	0	1	0	3	5	3	21
1430	5	2	2	9	2	0	0	1	0	0	2	21
1500	7	1	0	14	1	0	1	1	0	1	2	26
1530	4	1	1	8	4	0	1	0	0	0	5	19
1600	4	3	5	13	5	0	0	0	0	1	5	31
1630	7	3	0	9	2	0	0	1	0	0	2	22
1700	6	1	3	14	8	0	0	0	1	1	8	36
1730	6	0	1	2	5	0	0	0	0	3	5	17
12HR TOTAL	105	34	25	181	88	3	11	11	13	31	102	502
DAY TOTAL	105	34	25	181	88	3	11	11	13	31	102	502

LESOTHO VEHICLE WEIGHT SURVEY

ANALYSIS OF TRAFFIC COUNTS

STATION NO. 11  
LOCATION: MAPUTSOE

DATE: 01279  
DIRECTION: WEST

HALF HOUR BEGINNING	CARS	COMBIS	LAND ROVERS	PICKUPS	SINGLE UNIT	ARTICULATED	TRUCK + TRAILERS	BUSES	TAXIS	OTHER	TOTAL TRUCKS	TOTAL VEHICLES
600	1	0	0	0	1	0	1	0	0	0	2	3
630	3	0	0	1	0	0	1	0	0	0	1	5
700	2	3	0	3	1	1	0	2	1	1	2	14
730	4	2	1	11	3	0	0	1	0	2	3	24
800	6	1	1	6	5	0	0	1	0	3	5	23
830	3	2	1	6	3	0	0	0	0	7	3	22
900	2	2	1	9	3	0	0	2	0	4	3	23
930	3	2	0	10	5	0	1	1	0	7	6	29
1000	3	4	2	9	4	0	0	1	1	1	4	25
1030	1	3	1	7	1	0	1	0	1	0	2	15
1100	9	4	1	13	3	0	1	0	1	0	4	32
1130	4	1	0	10	6	1	0	1	2	6	7	31
1200	7	0	3	4	4	0	1	0	0	1	5	20
1230	8	0	1	2	1	0	0	1	0	2	1	15
1300	2	1	7	2	0	0	0	0	1	2	0	15
1330	1	3	1	8	1	0	0	1	0	3	1	18
1400	3	3	3	9	3	1	0	0	5	3	4	30
1430	10	3	2	6	7	0	1	0	0	2	8	31
1500	5	1	1	11	2	0	1	0	2	1	3	24
1530	4	2	0	9	0	1	1	1	0	1	2	19
1600	5	0	1	12	2	0	1	1	1	1	3	24
1630	3	1	0	2	4	0	2	0	0	0	6	12
1700	5	3	1	7	5	1	0	0	0	0	6	22
12HR TOTAL	94	41	28	157	64	5	12	13	15	47	81	476
DAY TOTAL	94	41	28	157	64	5	12	13	15	47	81	476

END OF PROGRAM WRITTEN 28 JANUARY 1980 R.S.

APPENDIX 4

## BIBLIOGRAPHY

A Portable Wheel Weighing Unit and Data Recorder LR391-Transport Road Research Laboratory U.K. 1971.

Single Track Roads in the Scottish Highlands LR71-Transport & Road Research Laboratory U.K. 1967.

Techno-Economic Feasibility Study of the Lesotho Southern Perimeter Road-Louis Berger International Inc. 1978.

Final Report on Vehicle Weight Control Program. Transport Investment Plan and Construction Materials Demand and Supply-CPTV, Republic of Guyana, Frederic R. Harris Inc. 1979.

Principles of Pavement Design 2nd. Edition E.J. Yoder and M.W. Witczak, Wiley 1975.